

When Networks Compute:

From Connectivity to Deterministic Execution in 6G



Johan Eker,
Ericsson Research & Lund University

Gradually, then suddenly

Mobile Network Evolution

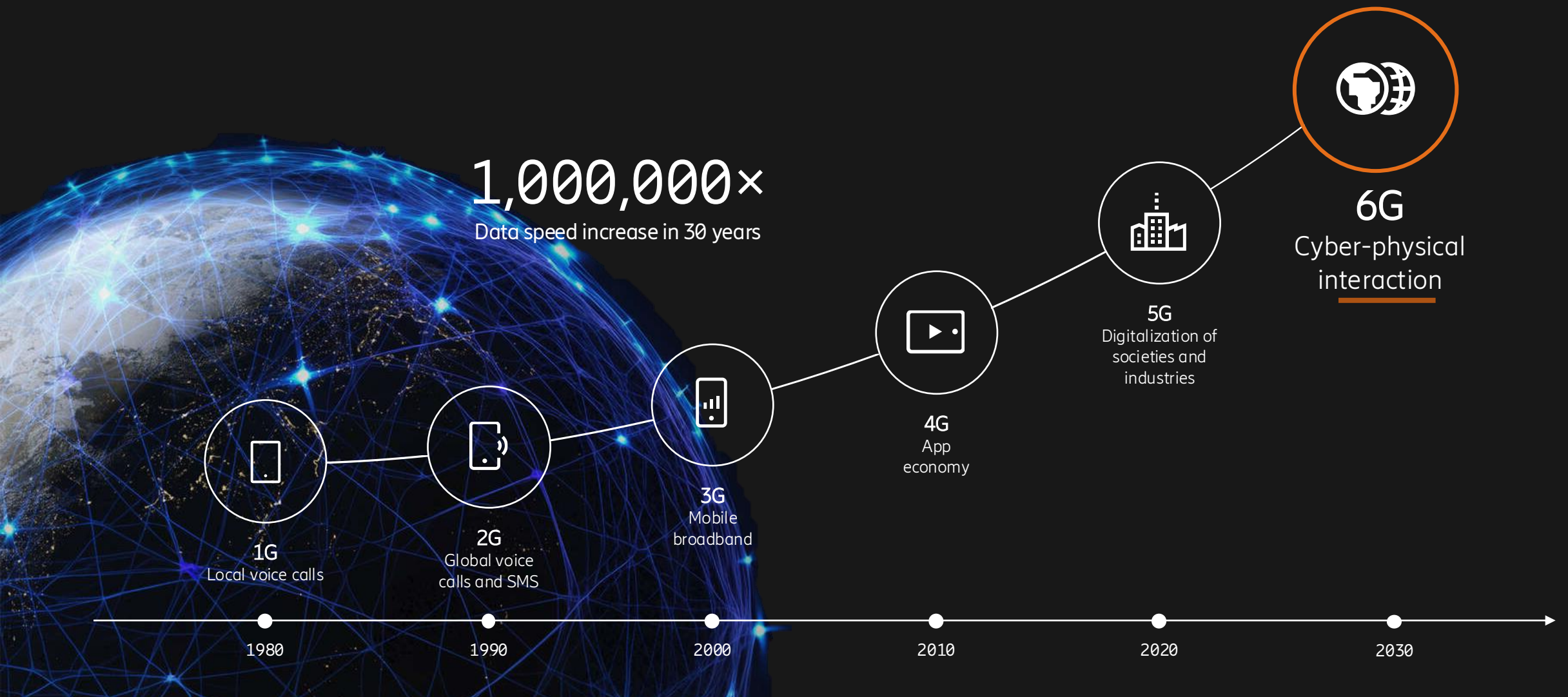

5G



Three Main Uses Cases Behind 5G



Massive



LOW COST, LOW ENERGY
SMALL DATA VOLUMES
MASSIVE NUMBERS

Critical



ULTRA RELIABLE
VERY LOW LATENCY
VERY HIGH AVAILABILITY

Enhanced mobile broadband

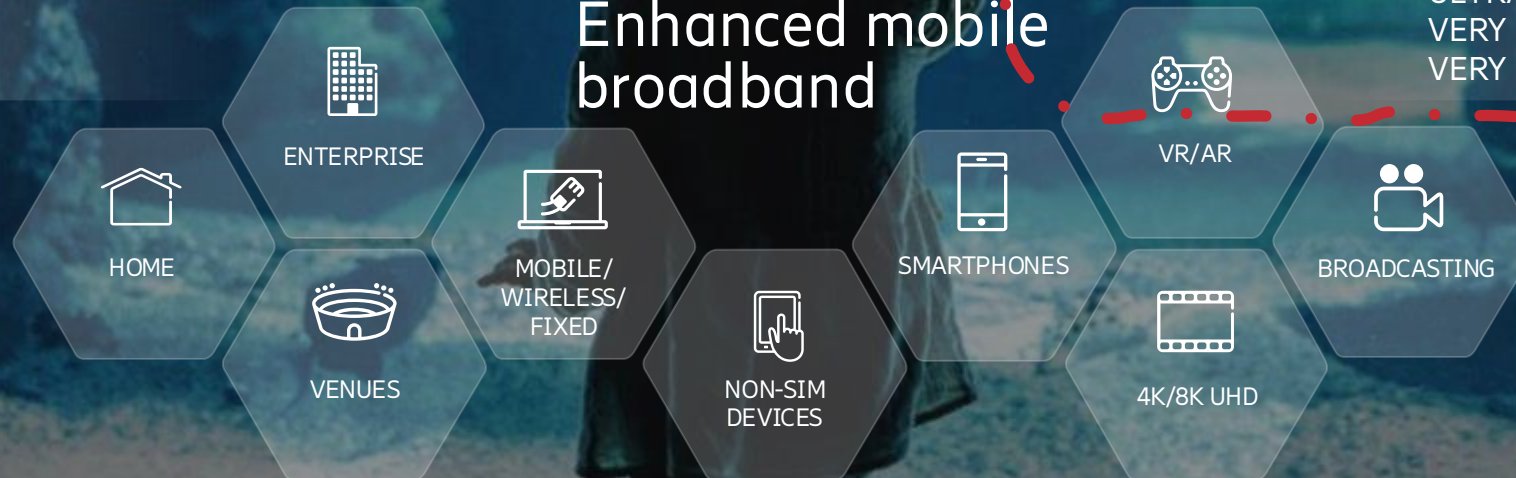

5G Radio Low Latency Features

eMBB

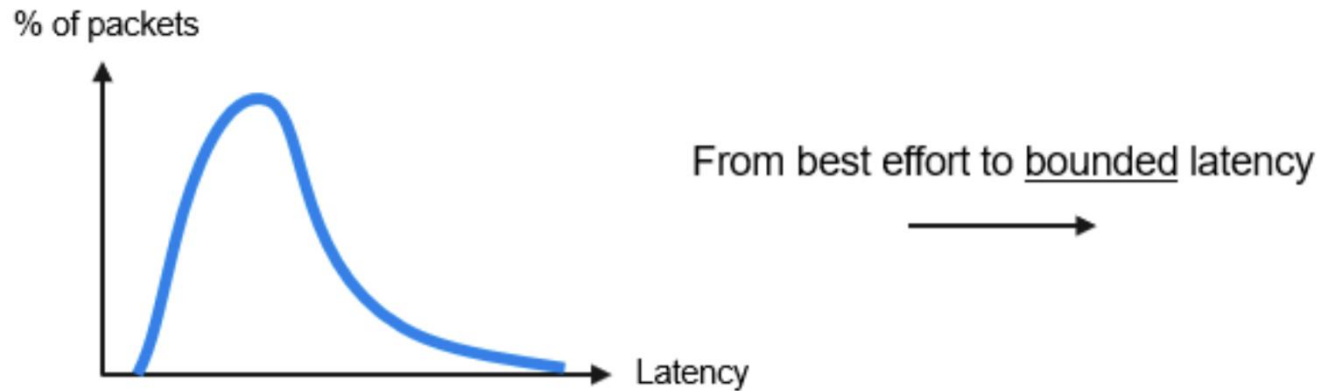

Time-Critical Communication

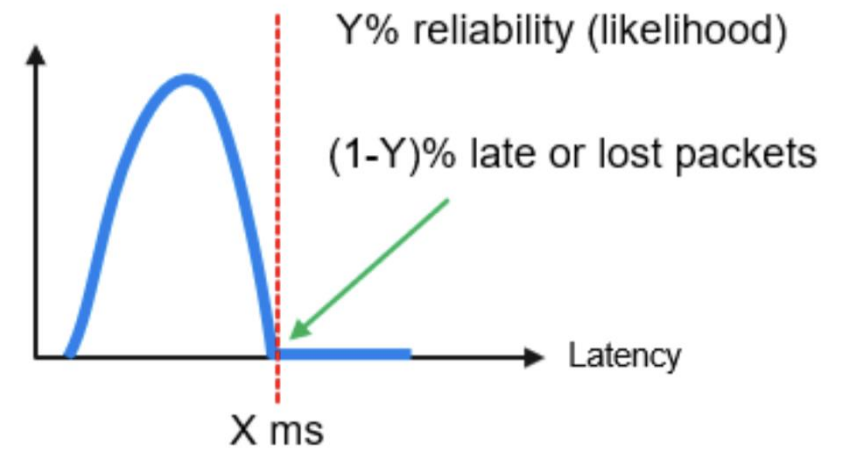

5G radio Low Latency Features

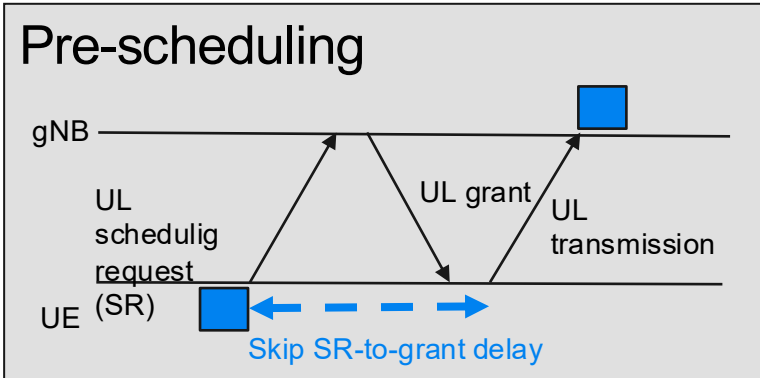

Pre-allocation of transmission resources for critical data stream

Reduces channel access times for the transmission

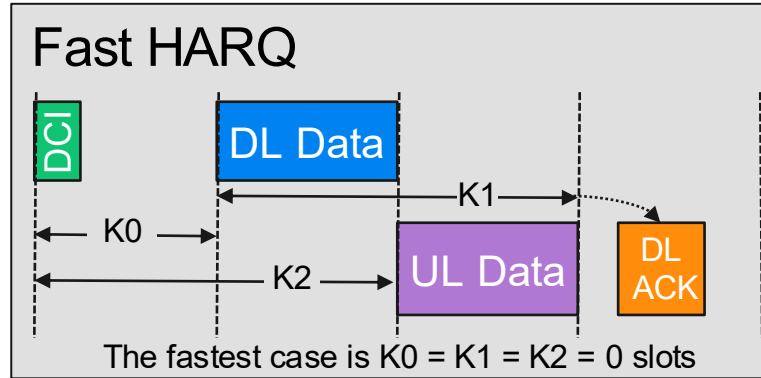

With $K_0 = K_1 = K_2 = 0$, the entire *DCI* → *DL data* → *ACK loop* completes within a single slot

Enables faster retransmissions

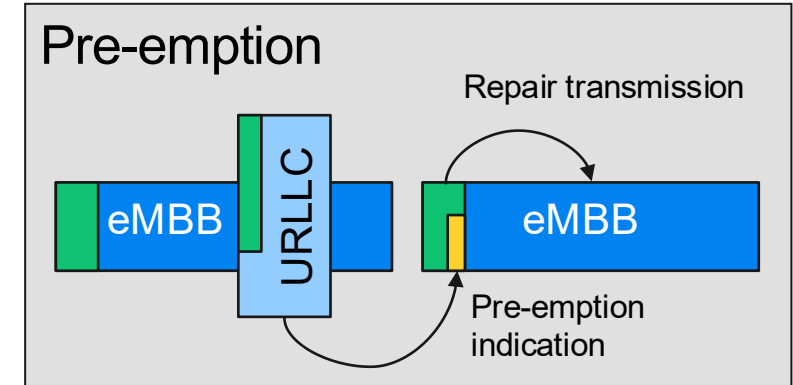

Critical data streams can interrupt best-effort data transmission

- HARQ - hybrid automatic repeat request
- gNB - 5G base station
- UE - 5G device
- UL / DL - uplink / downlink
- eMBB - enhanced mobile broadband
- URLLC - ultra-reliable and low latency communication
- DCI - Downlink control information



5G radio Low Latency Features

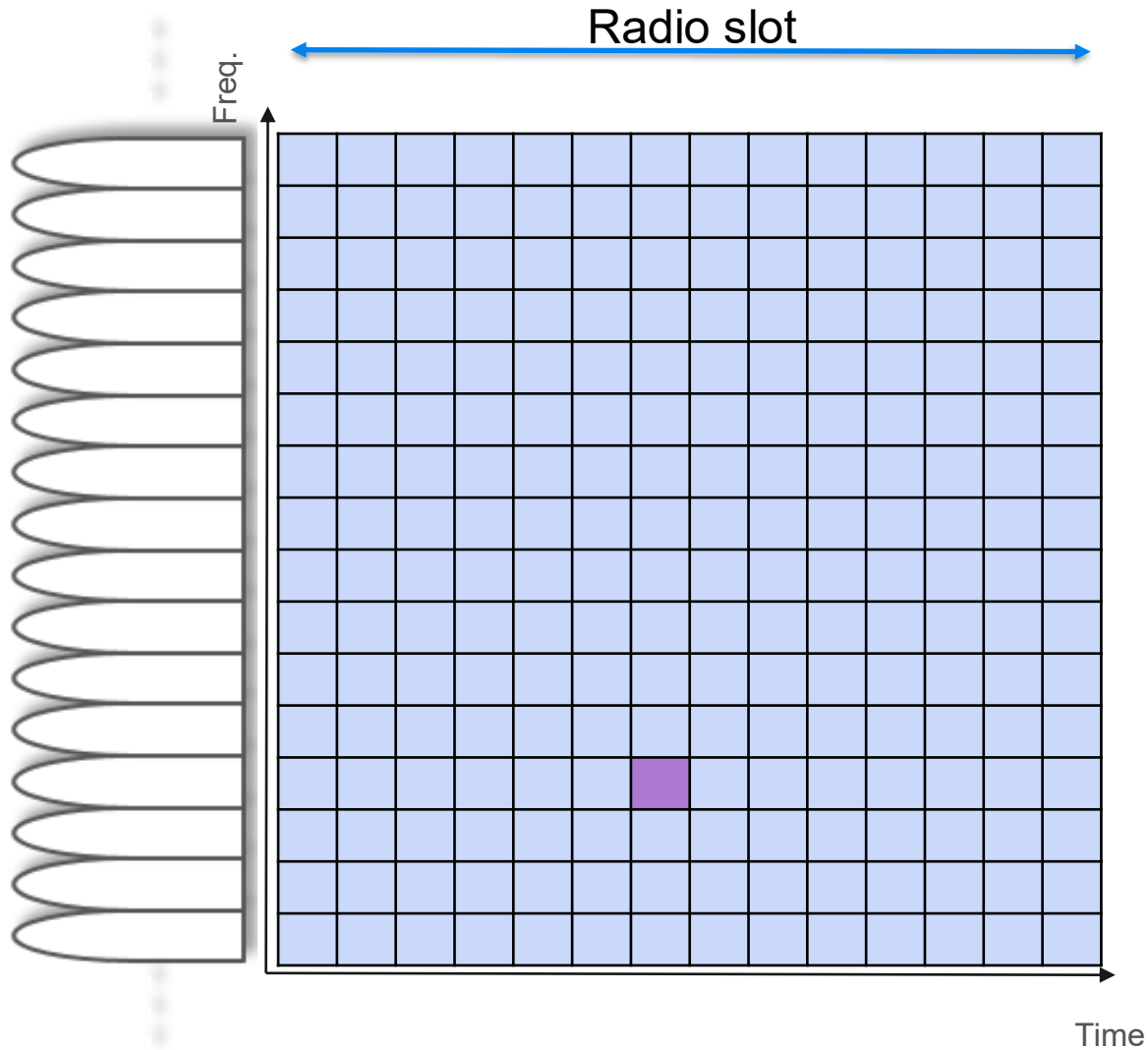

μ	SCS [kHz]	Slot duration
0	15	1 ms
1	30	0.5 ms
2	60	0.25 ms
3	120	0.125 ms
4	240	0.0625 ms

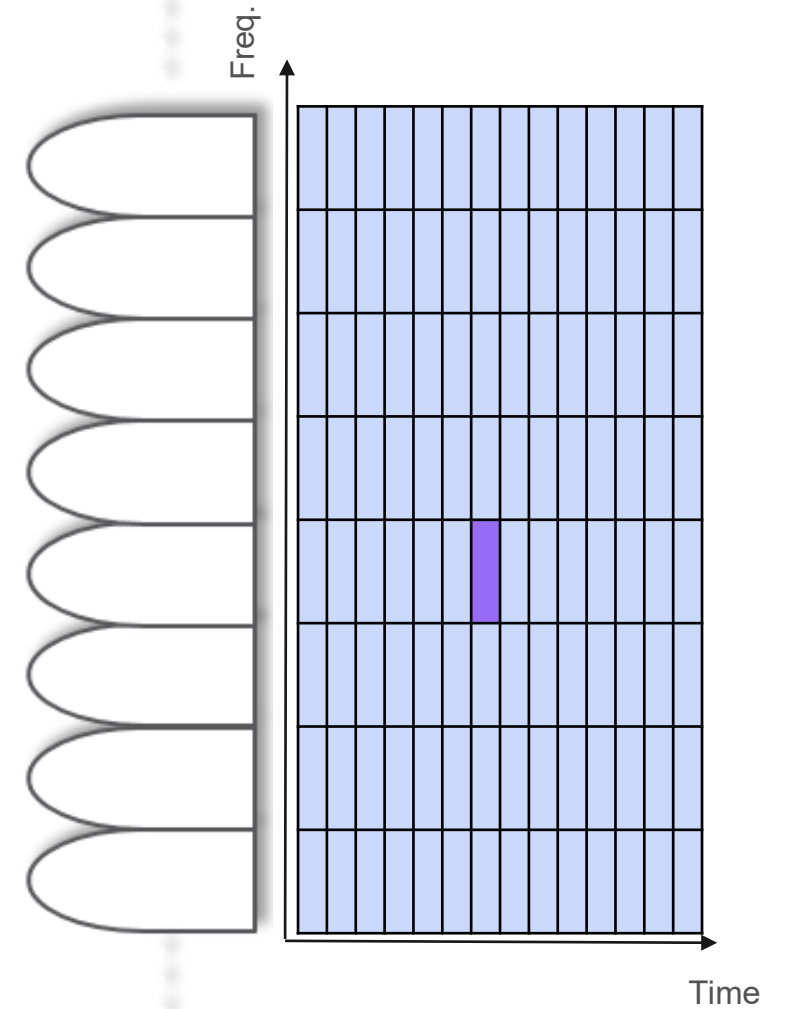
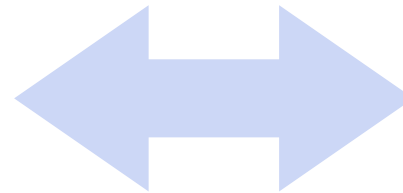

Low latency through short transmissions



Time-Critical Communication: Slices

A way to package all the different features

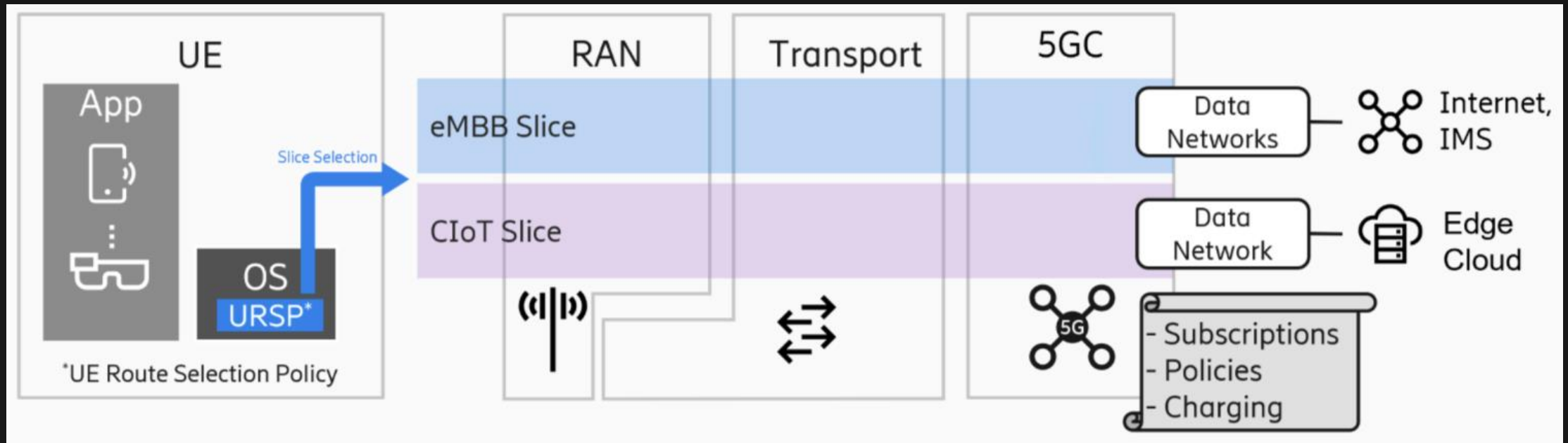

5G – Convergence Between IT & Network

The way we build networks has changed

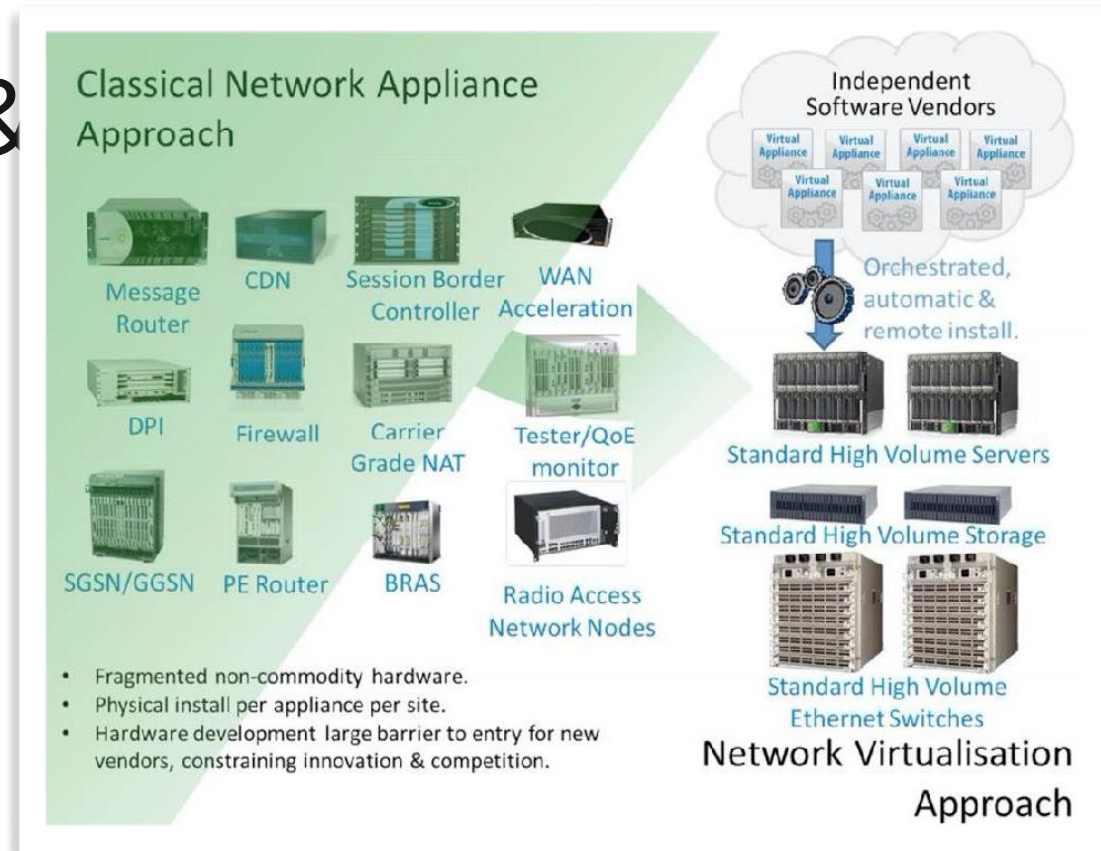
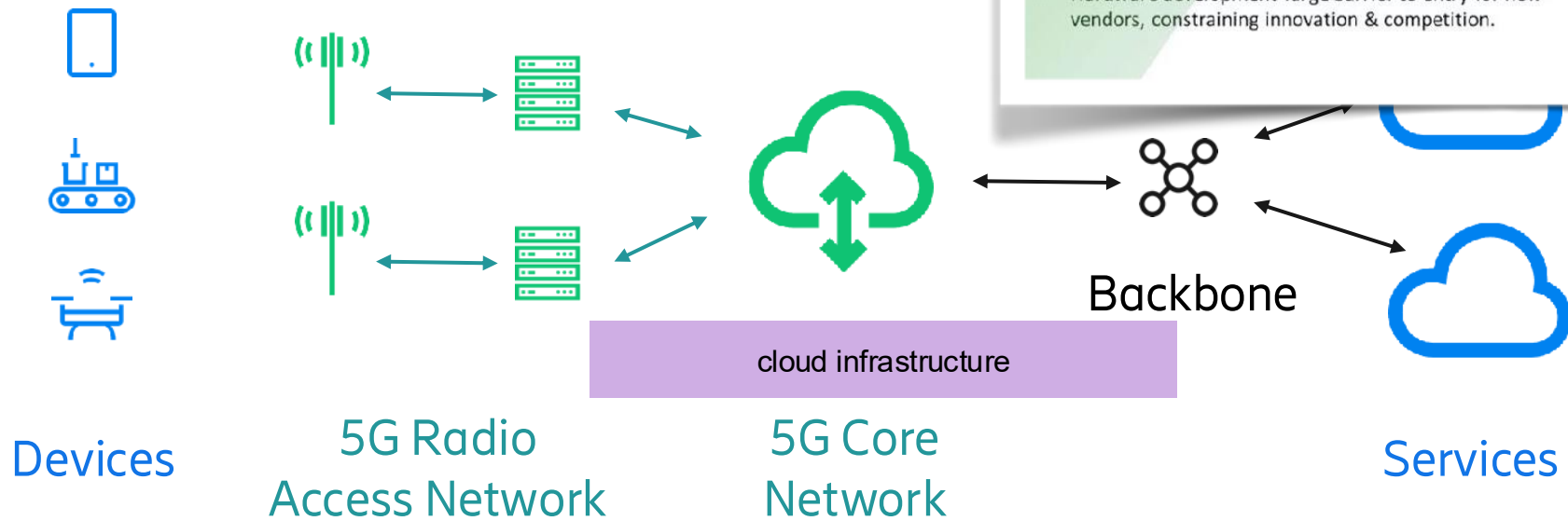



6G

6G is happening as I speak

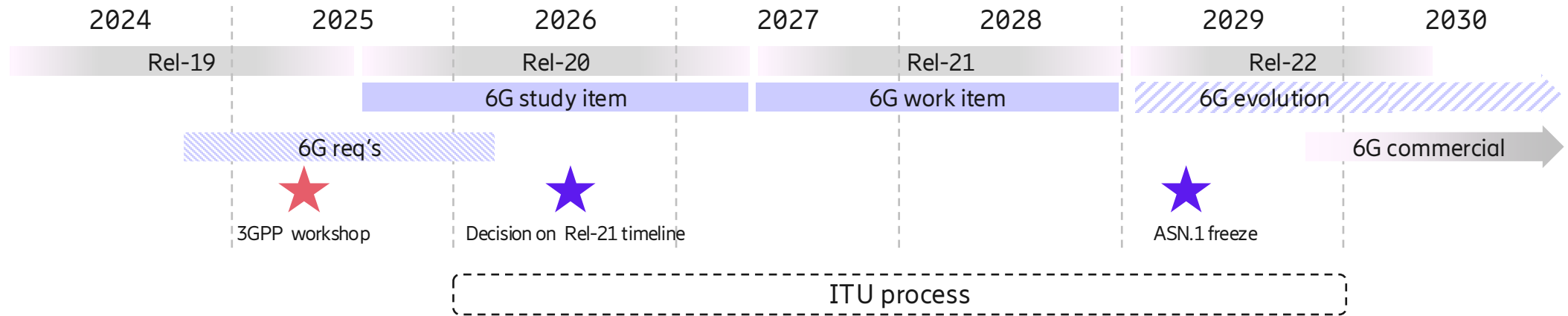

Some Driving 6G Use Cases

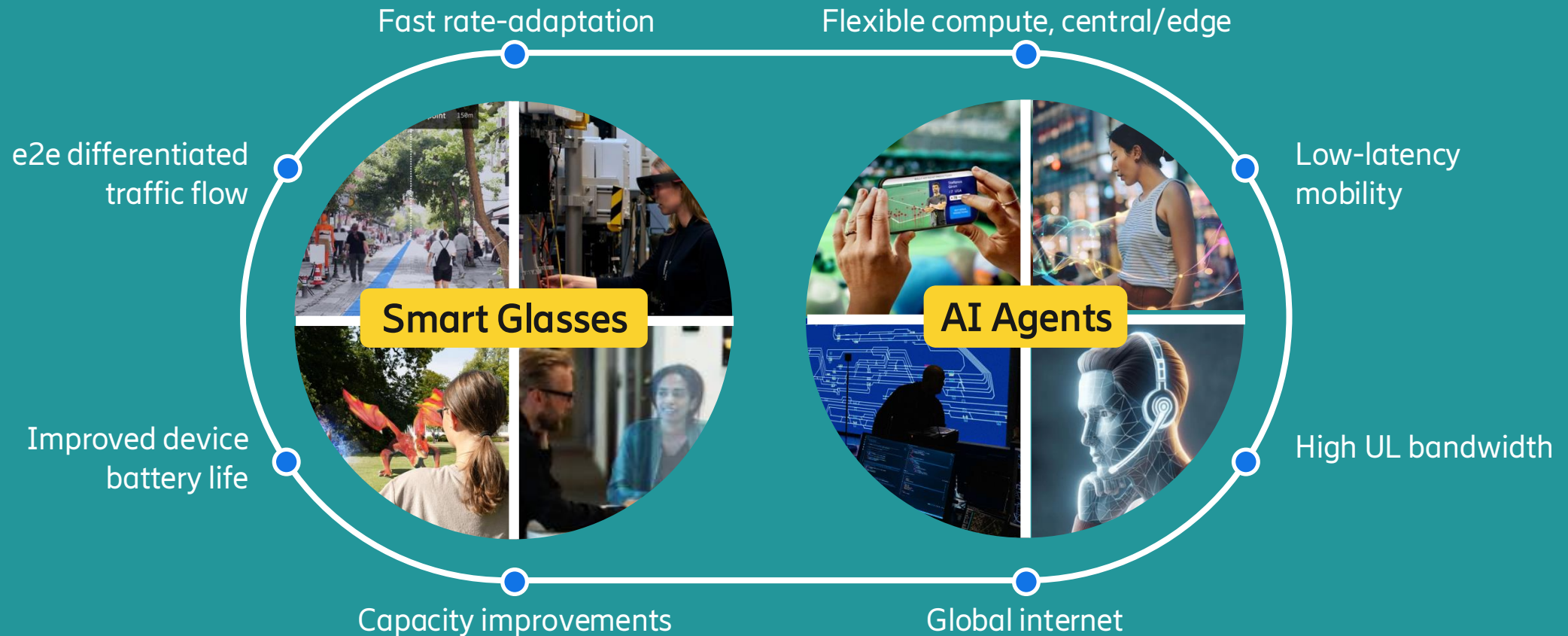

Enhanced capabilities (carried over from 5G, with improvements)

Capability	IMT-2020 (5G)	IMT-2030 (6G) target
Peak data rate Max ideal rate per device	20 Gbit/s	50 / 100 / 200 Gbit/s
User experienced data rate Available across coverage area	100 Mbit/s	300 / 500 Mbit/s
Spectrum efficiency Throughput per Hz per cell	1x	1.5x to 3x over 5G
Area traffic capacity Total throughput per m ²	10 Mbit/s/m ²	30 / 50 Mbit/s/m ²
Connection density Devices per km ²	10 ⁶ /km ²	10 ⁶ to 10 ⁸ /km ²
Mobility Speed at which service holds	500 km/h	500 to 1000 km/h
Latency One-way over-the-air	1 ms	0.1 to 1 ms
Reliability Probability of success	1-10 ⁻⁵	1-10 ⁻⁵ to 1-10 ⁻⁷
Security and resilience Privacy, attack resilience	Baseline	Enhanced, quantum-safe

New capabilities (not in 5G)

Coverage Includes non-terrestrial	Near 100% global
Positioning Accuracy of location estimate	1 to 10 cm
Sensing Detection, localization, velocity	Native ISAC support
AI-related capabilities Training, inference, model exchange	AI as native service
Sustainability Energy efficiency per bit	~100x energy efficiency
Interoperability Vendors, networks, standards	Open, member-inclusive

6G performance *potential* – some early examples

Energy efficiency

Up to **77%**

reduction in network energy consumption at low loads by reducing the transmission of always-on signals

Up to **35%**

reduction in modem energy consumption by wake-up signals and other power-saving mechanisms

Capacity and throughput

Up to **+200%**

downlink capacity increase by adding cm-wave spectrum with massive MIMO on the existing site grid

Up to **+150%**

cell-edge user throughput by deploying massive MIMO radios also on the FDD bands

Uplink performance

Up to **+56%**

experienced uplink data rates for small packets by redesigning and streamlining scheduling and control signaling

Up to **10X**

uplink throughput for cell-edge users at low load by selecting the frequency band independently for uplink and downlink

New service opportunities

Up to **+23%**

positioning accuracy using AI-based positioning algorithms capable of learning and exploring the environment

2-3m

average error in ISAC drone tracking in horizontal location using a live test communication network

6G is a platform

APIs for differentiated connectivity services



APIs for information, compute and AI services



Transport data for anything, anywhere

Process & store data

Be a source of data

Better direct interaction with the app ecosystem

Network taking a bigger role in the combined ecosystem

CAMARA: Open Network APIs

Linux Foundation open-source project defining standardized APIs for exposing telecom network capabilities to developers.

API Families

- Quality on Demand
- Location Verification
- SIM Swap (fraud)
- Network Slice Booking
- Device Connectivity

<https://camaraproject.org> | Apache 2.0 licensed | GSMA Open Gateway aligned

Some technology trends



Hardware
Generic HW (CPU,GPU),
Quantum technology,
New materials



Open source
Higher reliance on
open-source components



Integrated AI
Widespread use of AI for
automation and cost-efficiency in
cognitive and data-driven networks



Cloud
Continued cloudification for
cost/efficiency, also in RAN and in user
plane



Continuous evolution
Fast evolution of underlying tools
and development (DevOps)
at a higher pace

6G - Even the radio access network will run in the cloud

Again, we change the way we build networks

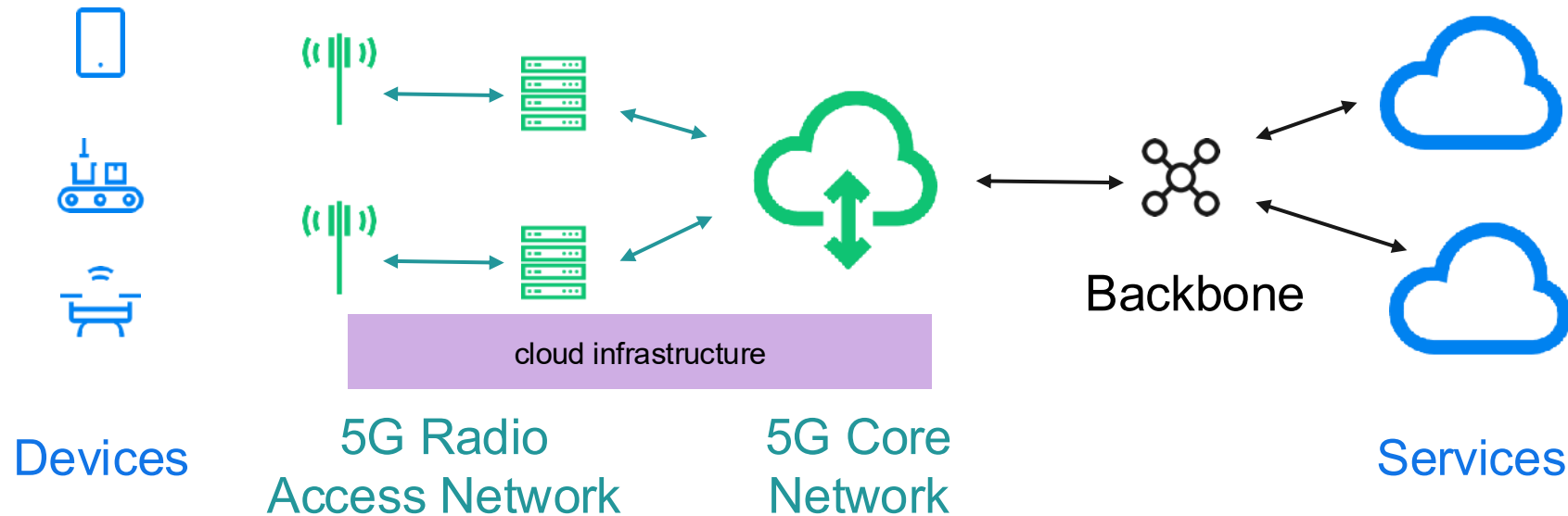



ISAAC

Integrated Sensing and Communication (ISAC)

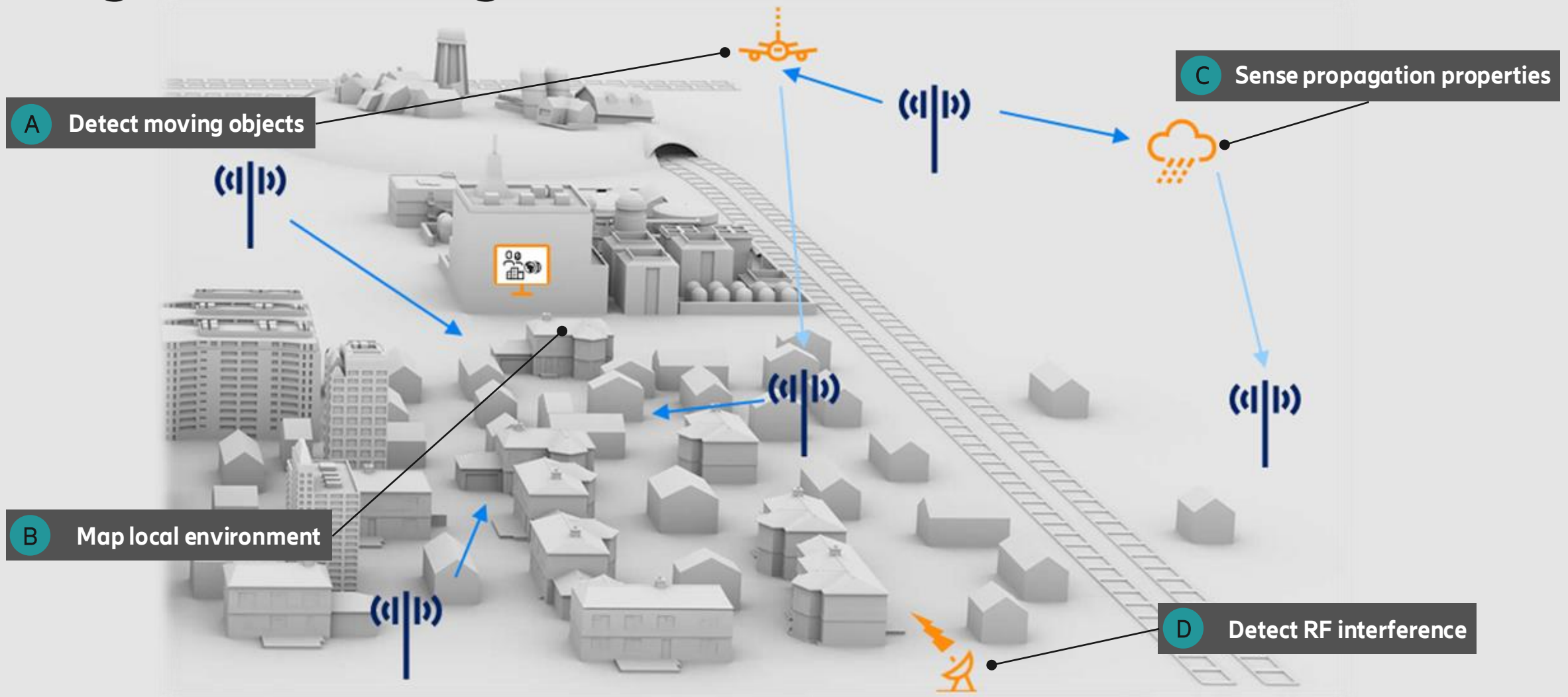

ISAC is completely passive localization

Detect a moving drone, a car, a cyclist, and a person

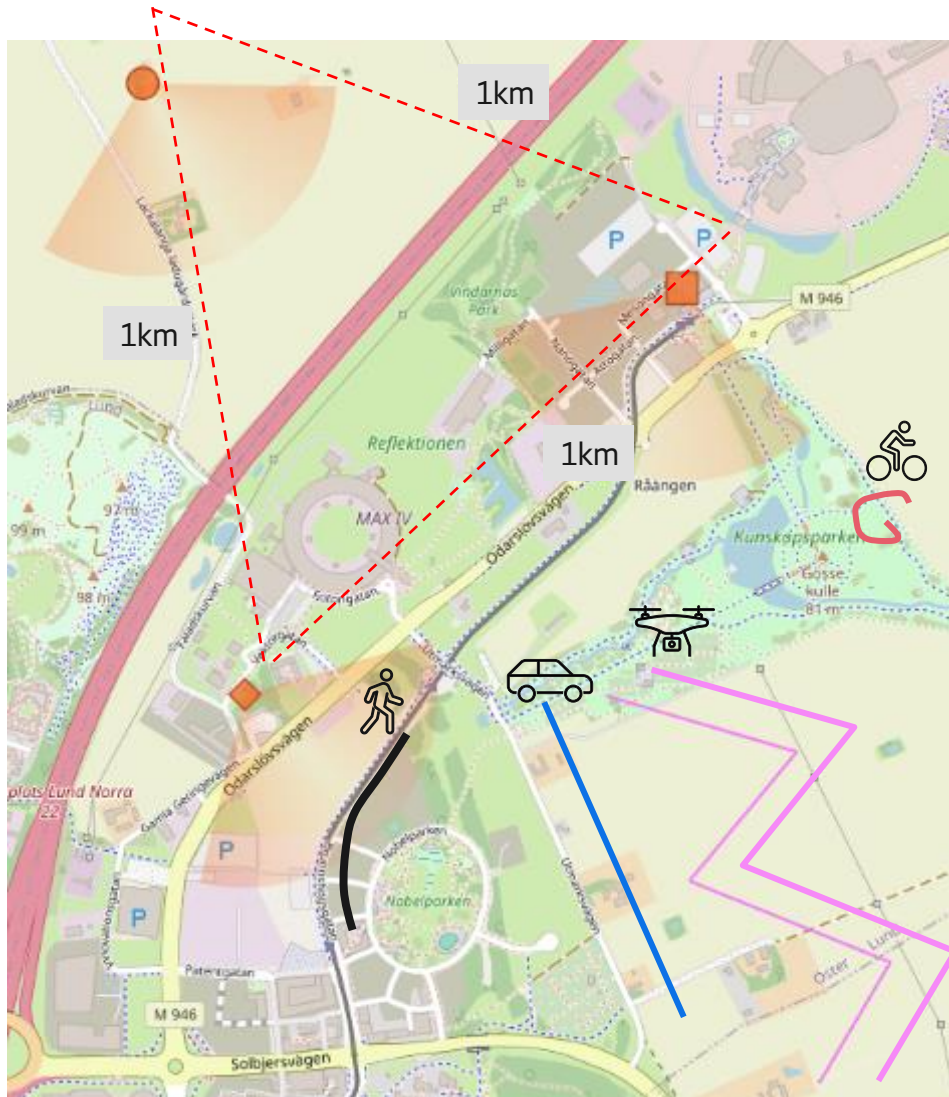

~1 km site-to-site distance (alternating Tx/Rx)

Site height 30-45 meters, realistic downtilts

2.2-3.5 km: Tx-drone-Rx distance

Drone height 75 m, speed ~ 20-25 km/h

10-15 m ground truth drone GPS reporting capability accuracy

- Drone route
- Car track
- Bicycle
- Person



Sensing Deployment Overview

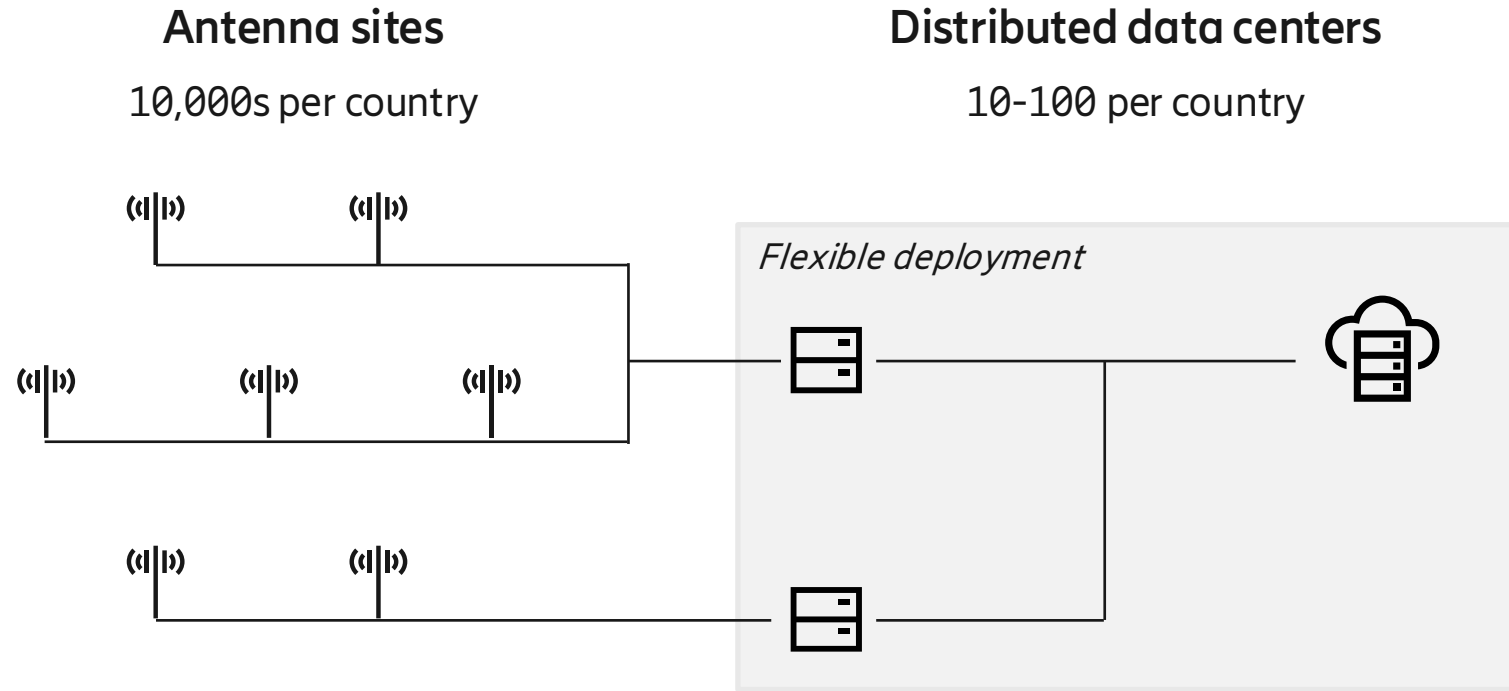

**Sensing processing at the edge
require compute**

- Sensing management
- Fusion and aggregation
- Object classification
- Policy control and exposure



OFF
LOADING

Why Offload?

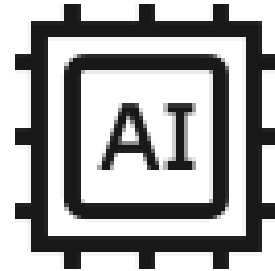

Dynamic device offloading



Bring your own code



Deploy anywhere



Adapt dynamically

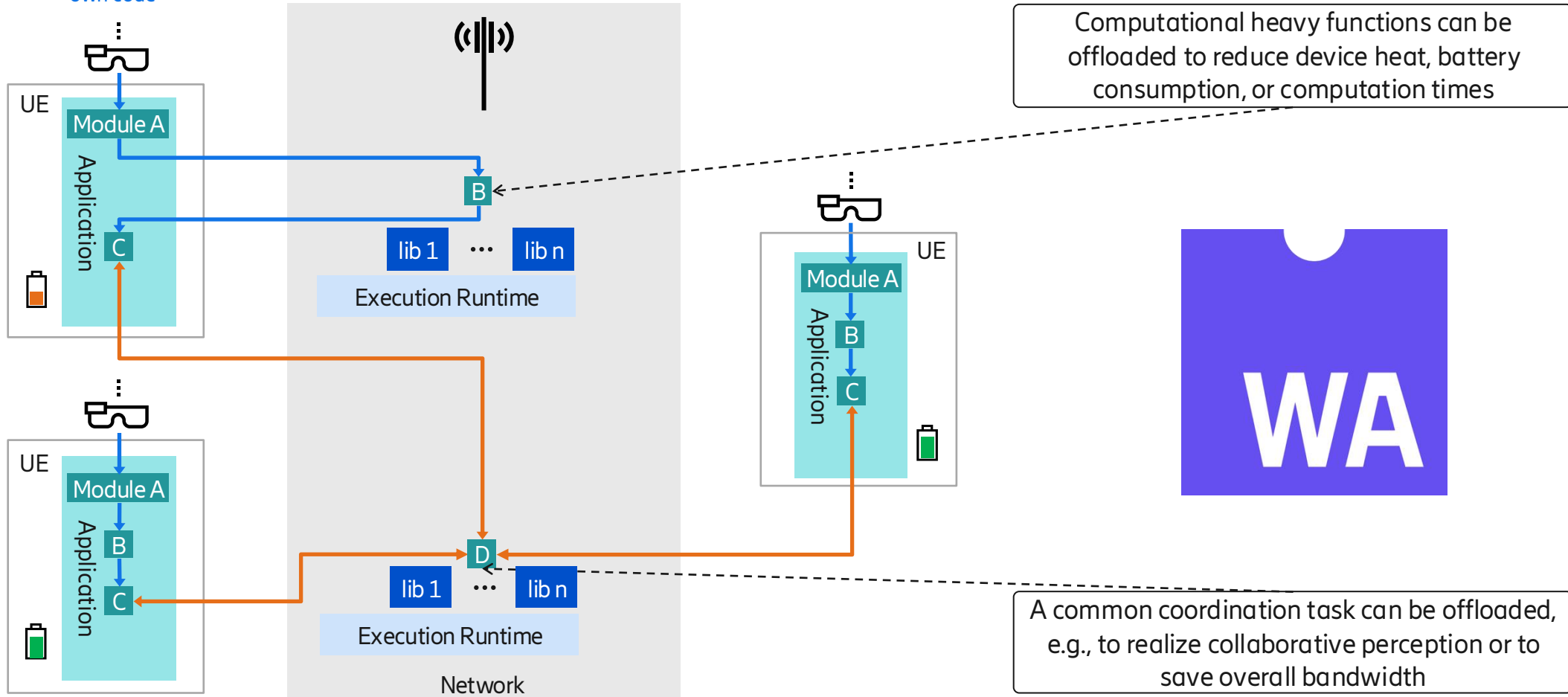

Consider a mobile search & rescue scenario

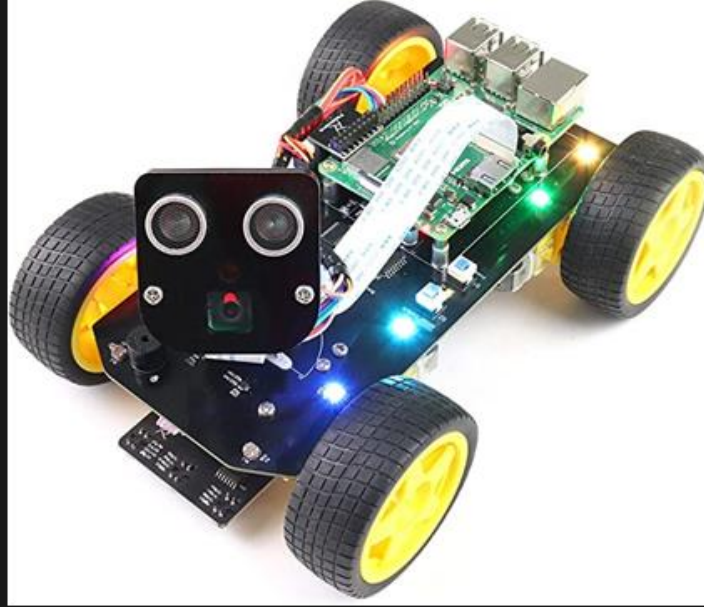

Our Testbed in Lünd





ERDC



E-huset

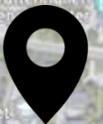

M-huset

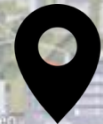



REAL TIME

From Connectivity to Deterministic Execution

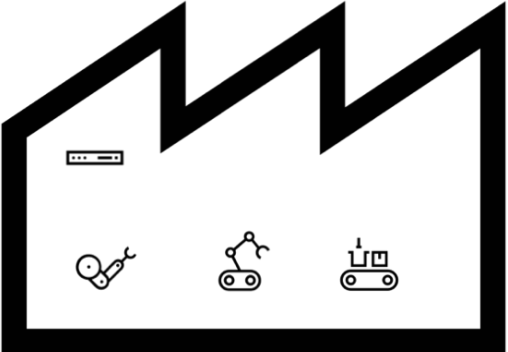
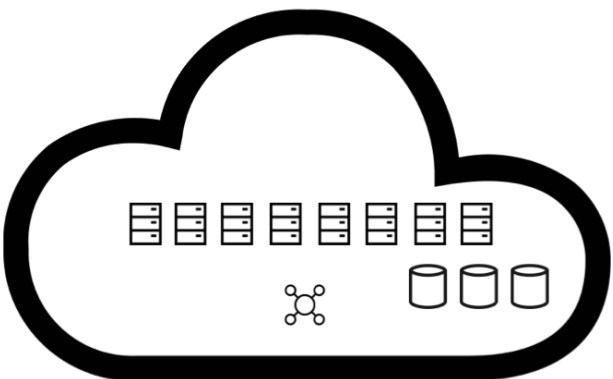

end-2-end deadline

Provide deterministic and predictable round-trip latencies – What is missing?

Real-time cloud: end-to-end

Time sensitive comm.

Bounded latency transport (URLLC, TSN, DetNet)

Transport redundancy

Network exposure

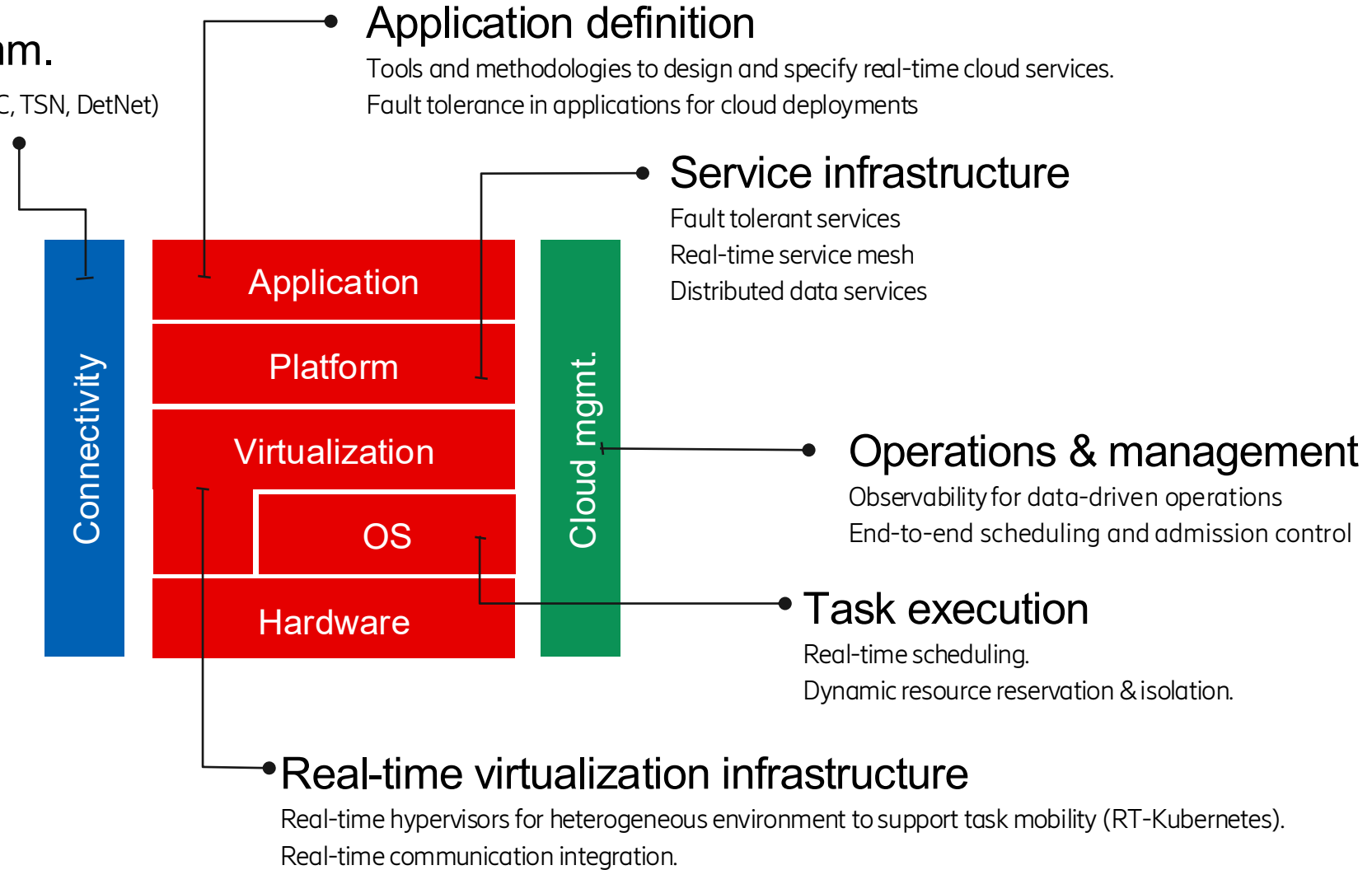



SUMMARY

Research questions

End-to-end coordination

Compute & communication co-design

Robustness beats optimality

Ownership in zero-trust environments

Take away: 6G is a platform

APIs for differentiated connectivity services



APIs for information, compute and AI services



Transport data for anything, anywhere

Process & store data

Be a source of data



ERICSSON

ericsson.com/6g