



Centre for Visual Analytics
Science & Technology

Illuminating Change: *Context-Aware Visual Analytics Across Space and Time*

TU Wien

Silvia Miksch & Team

www.cvast.tuwien.ac.at



Informatics

[2005]

illuminating the Path

The Research and Development Agenda
for
Visual Analytics

Edited by James J. Thomas and Kristin A. Cook



National Visualization and Analytics Center™



illuminating **Change:**

*Context-Aware Visual
Analytics Across
Space and Time*

Content

Motivation & Contextualization

Data, Users, & Tasks → Information & Knowledge

Visual Analytics (VA)

Mixed-Initiative Process & Challenges

Guidance-Enriched VA

Models and Concepts

Exempels & Insights

Knowledge-Assisted VA

Models and Concepts

Exempels & Insights

Challenges & Opportunities

Conclusion





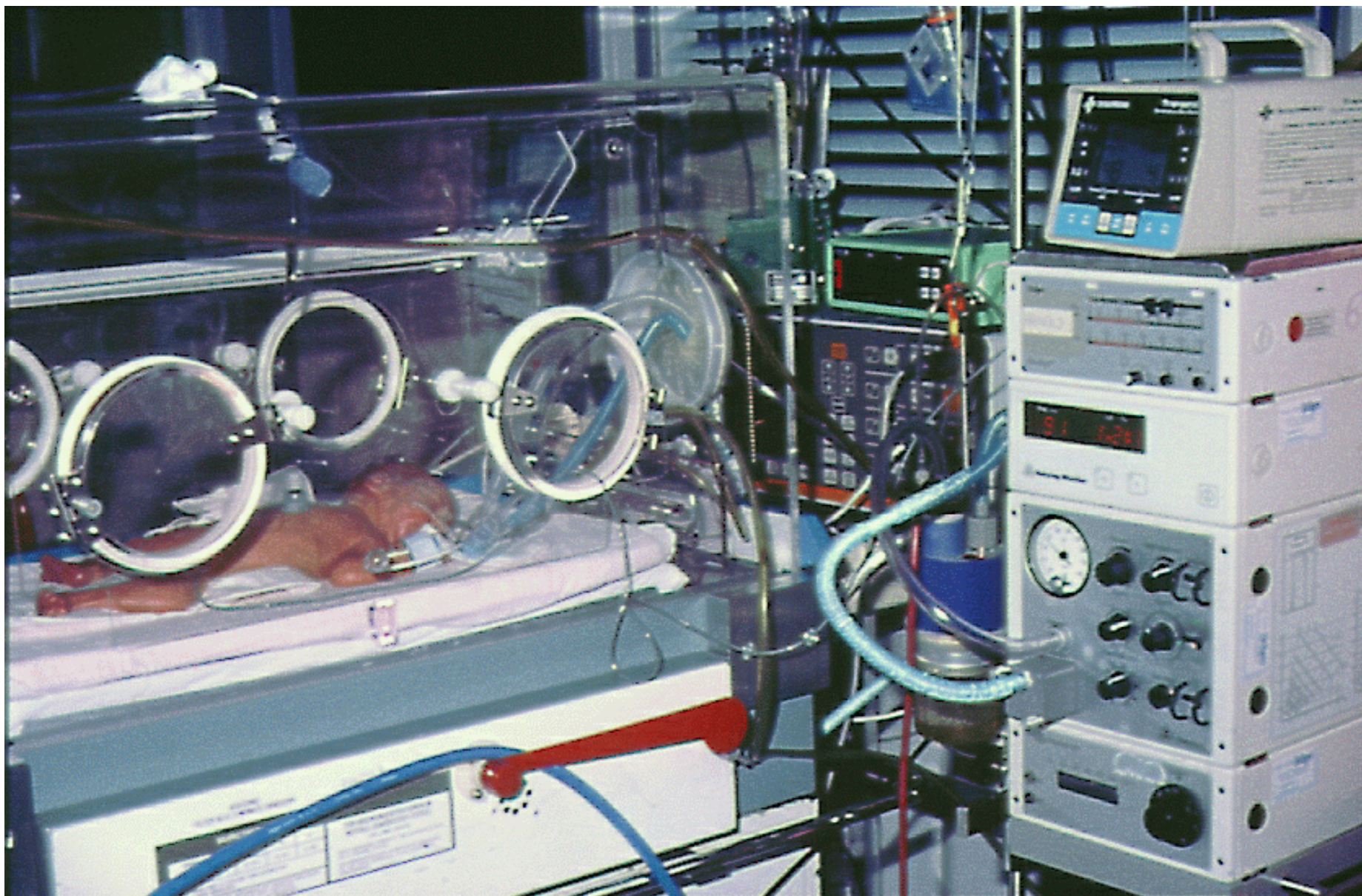



Which Information to Tackle ...

Data

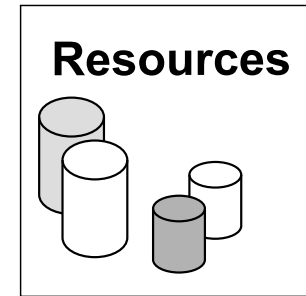
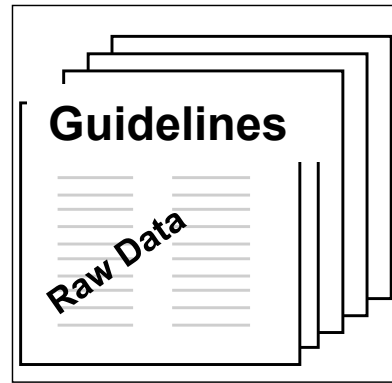
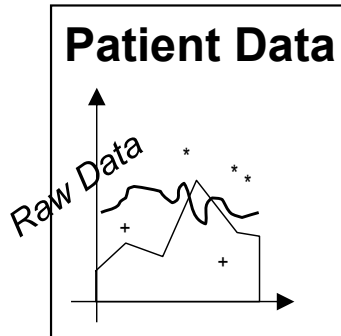

Users

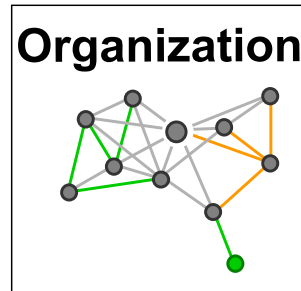
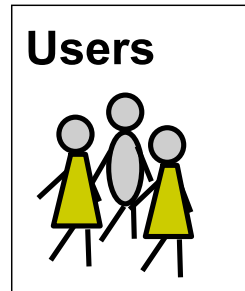

Tasks

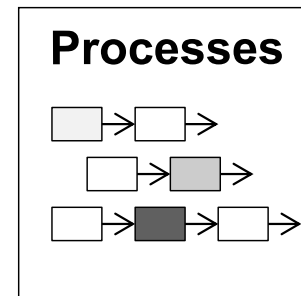
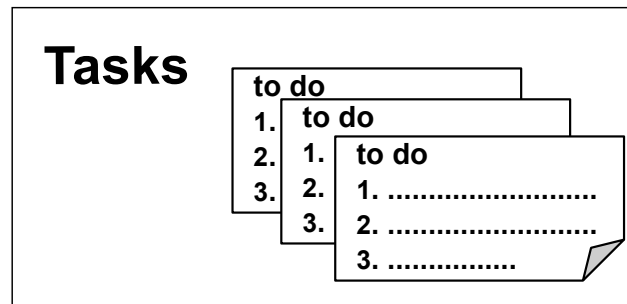

... Change over Time

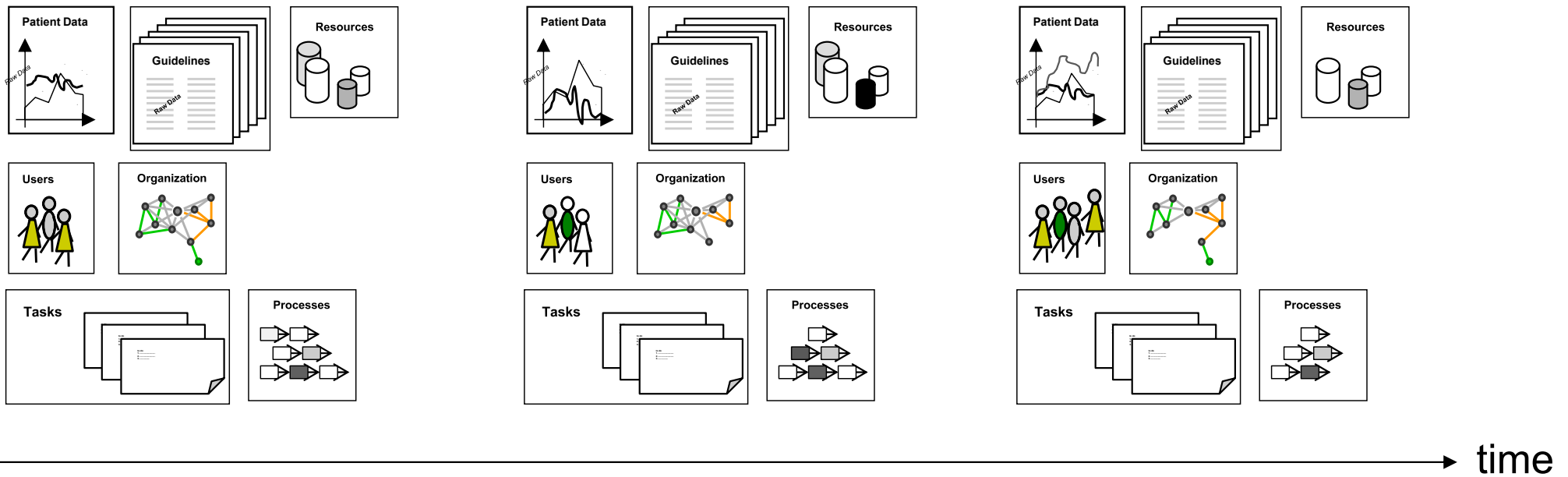

Data & Information

*time-oriented, multivariate, irregular sampled,
having different temporal granularities, qualitative, quantitative, etc.*

→ *structured and unstructured enriched by meta data*

variables

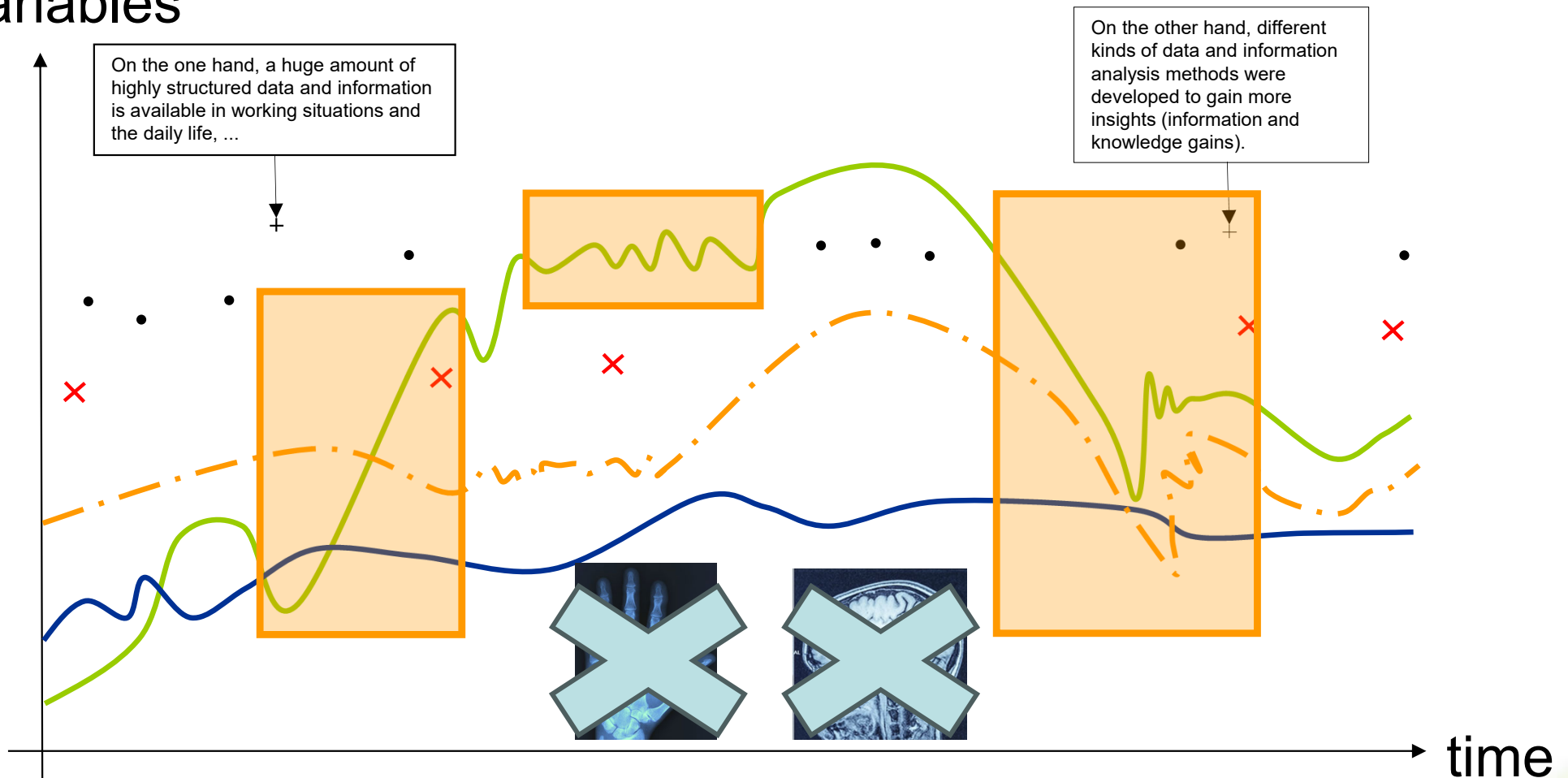

WHY VISUALIZATION?



Anscombe's Quartet

Anscombe's quartet

I		II		III		IV	
x	y	x	y	x	y	x	y
10.0	8.04	10.0	9.14	10.0	7.46	8.0	6.58
8.0	6.95	8.0	8.14	8.0	6.77	8.0	5.76
13.0	7.58	13.0	8.74	13.0	12.74	8.0	7.71
9.0	8.81	9.0	8.77	9.0	7.11	8.0	8.84
11.0	8.33	11.0	9.26	11.0	7.81	8.0	8.47
14.0	9.96	14.0	8.10	14.0	8.84	8.0	7.04
6.0	7.24	6.0	6.13	6.0	6.08	8.0	5.25
4.0	4.26	4.0	3.10	4.0	5.39	19.0	12.50
12.0	10.84	12.0	9.13	12.0	8.15	8.0	5.56
7.0	4.82	7.0	7.26	7.0	6.42	8.0	7.91
5.0	5.68	5.0	4.74	5.0	5.73	8.0	6.89

Property	Value
Mean of x in each case	9 (exact)
Variance of x in each case	11 (exact)
Mean of y in each case	7.50 (to 2 decimal places)
Variance of y in each case	4.122 or 4.127 (to 3 decimal places)
Correlation between x and y in each case	0.816 (to 3 decimal places)
Linear regression line in each case	$y = 3.00 + 0.500x$ (to 2 and 3 decimal places, respectively)

[http://en.wikipedia.org/wiki/Anscombe's_quartet;
Anscombe, 1973]

Anscombe's Quartet

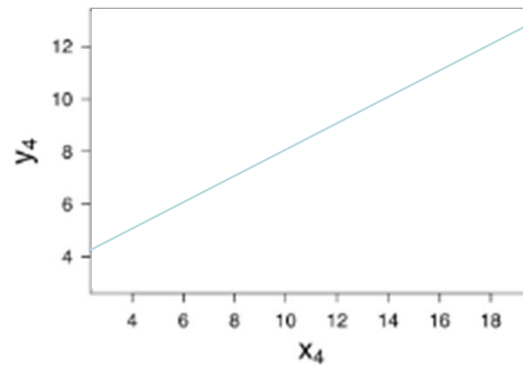
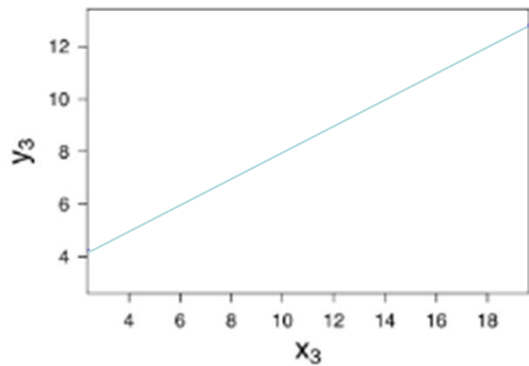
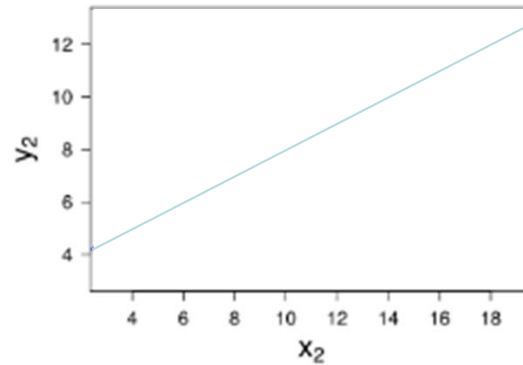
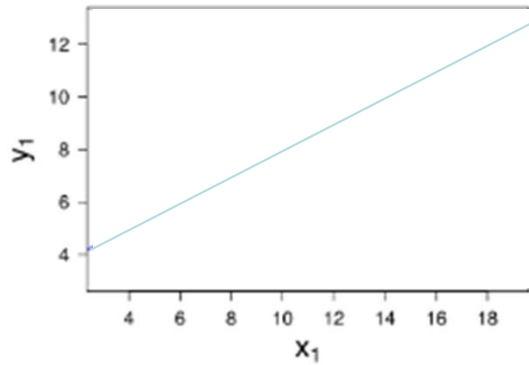

Anscombe's quartet

I		II		III		IV	
x	y	x	y	x	y	x	y
10.0	8.04	10.0	9.14	10.0	7.46	8.0	6.58
8.0	6.95	8.0	8.14	8.0	6.77	8.0	5.76
13.0	7.58	13.0	8.74	13.0	12.74	8.0	7.71
9.0	8.81	9.0	8.77	9.0	7.11	8.0	8.84
11.0	8.33	11.0	9.26	11.0	7.81	8.0	8.47
14.0	9.96	14.0	8.10	14.0	8.84	8.0	7.04
6.0	7.24	6.0	6.13	6.0	6.08	8.0	5.25
4.0	4.26	4.0	3.10	4.0	5.39	19.0	12.50
12.0	10.84	12.0	9.13	12.0	8.15	8.0	5.56
7.0	4.82	7.0	7.26	7.0	6.42	8.0	7.91
5.0	5.68	5.0	4.74	5.0	5.73	8.0	6.89

Property	Value
Mean of x in each case	9 (exact)
Variance of x in each case	11 (exact)
Mean of y in each case	7.50 (to 2 decimal places)
Variance of y in each case	4.122 or 4.127 (to 3 decimal places)
Correlation between x and y in each case	0.816 (to 3 decimal places)
Linear regression line in each case	$y = 3.00 + 0.500x$ (to 2 and 3 decimal places, respectively)

[http://en.wikipedia.org/wiki/Anscombe's_quartet;
Anscombe, 1973]

Anscombe's Quartet

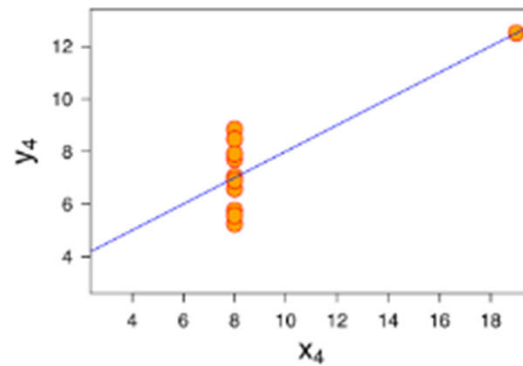
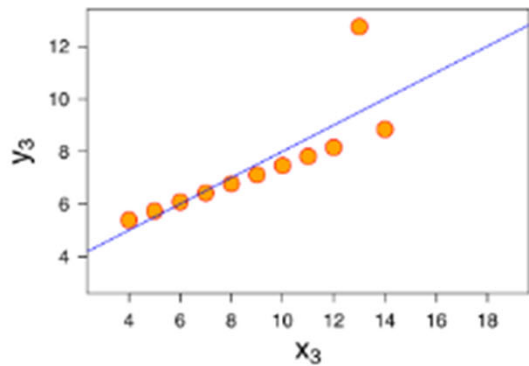
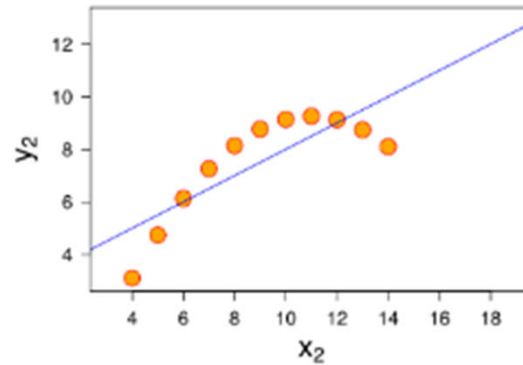
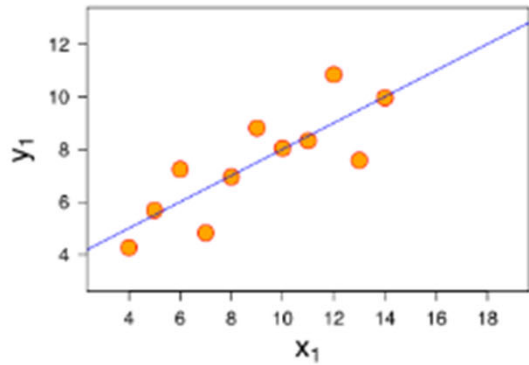

Anscombe's quartet

I		II		III		IV	
x	y	x	y	x	y	x	y
10.0	8.04	10.0	9.14	10.0	7.46	8.0	6.58
8.0	6.95	8.0	8.14	8.0	6.77	8.0	5.76
13.0	7.58	13.0	8.74	13.0	12.74	8.0	7.71
9.0	8.81	9.0	8.77	9.0	7.11	8.0	8.84
11.0	8.33	11.0	9.26	11.0	7.81	8.0	8.47
14.0	9.96	14.0	8.10	14.0	8.84	8.0	7.04
6.0	7.24	6.0	6.13	6.0	6.08	8.0	5.25
4.0	4.26	4.0	3.10	4.0	5.39	19.0	12.50
12.0	10.84	12.0	9.13	12.0	8.15	8.0	5.56
7.0	4.82	7.0	7.26	7.0	6.42	8.0	7.91
5.0	5.68	5.0	4.74	5.0	5.73	8.0	6.89

Property	Value
Mean of x in each case	9 (exact)
Variance of x in each case	11 (exact)
Mean of y in each case	7.50 (to 2 decimal places)
Variance of y in each case	4.122 or 4.127 (to 3 decimal places)
Correlation between x and y in each case	0.816 (to 3 decimal places)
Linear regression line in each case	$y = 3.00 + 0.500x$ (to 2 and 3 decimal places, respectively)

[http://en.wikipedia.org/wiki/Anscombe's_quartet;
Anscombe, 1973]

Same Stats, Different Graphs

[Matejka and Fitzmaurice, 2017]

→ *The hidden dinosaurs*

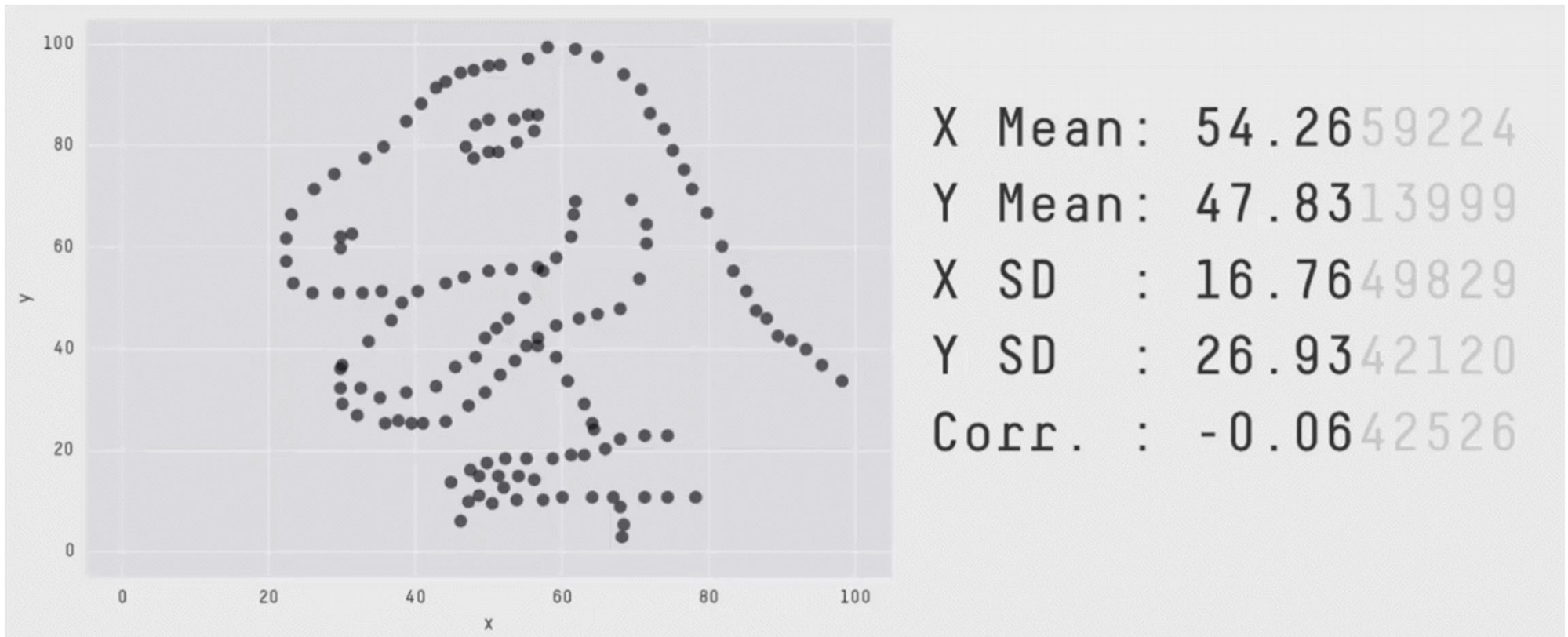

Visual Analytics – What is it?

James Thomas & Kristin A. Cook

NVAC (National Visualization and Analytics Center), Seattle, USA

*“Visual Analytics
is the science of analytical reasoning
facilitated by
interactive visual interfaces”*

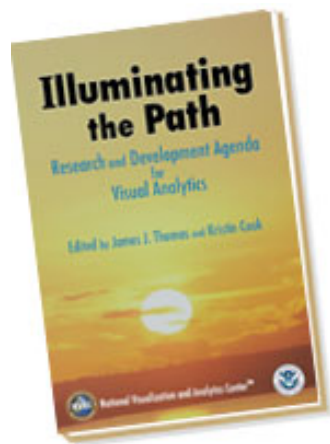

[Thomas & Cook 2005]

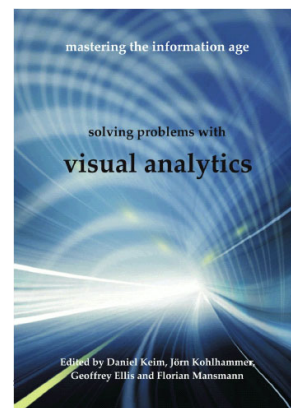

[Keim, et al. 2010]:
Miksch & Pohl contributions

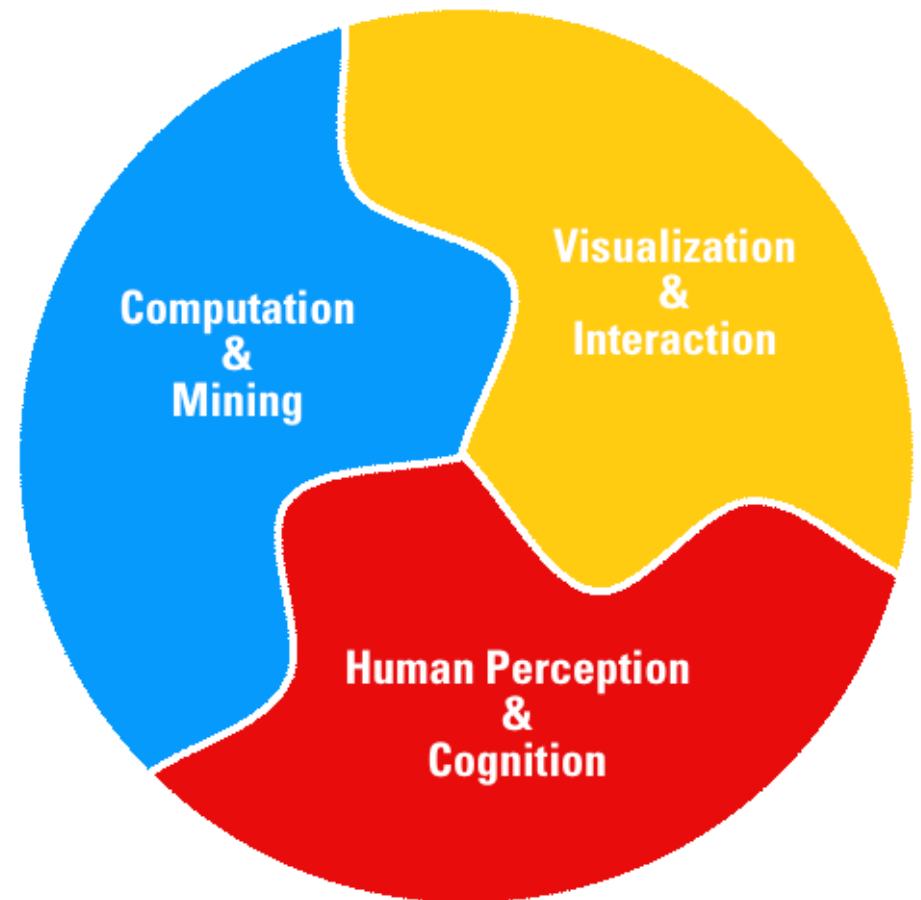

Visual Analytics – Process

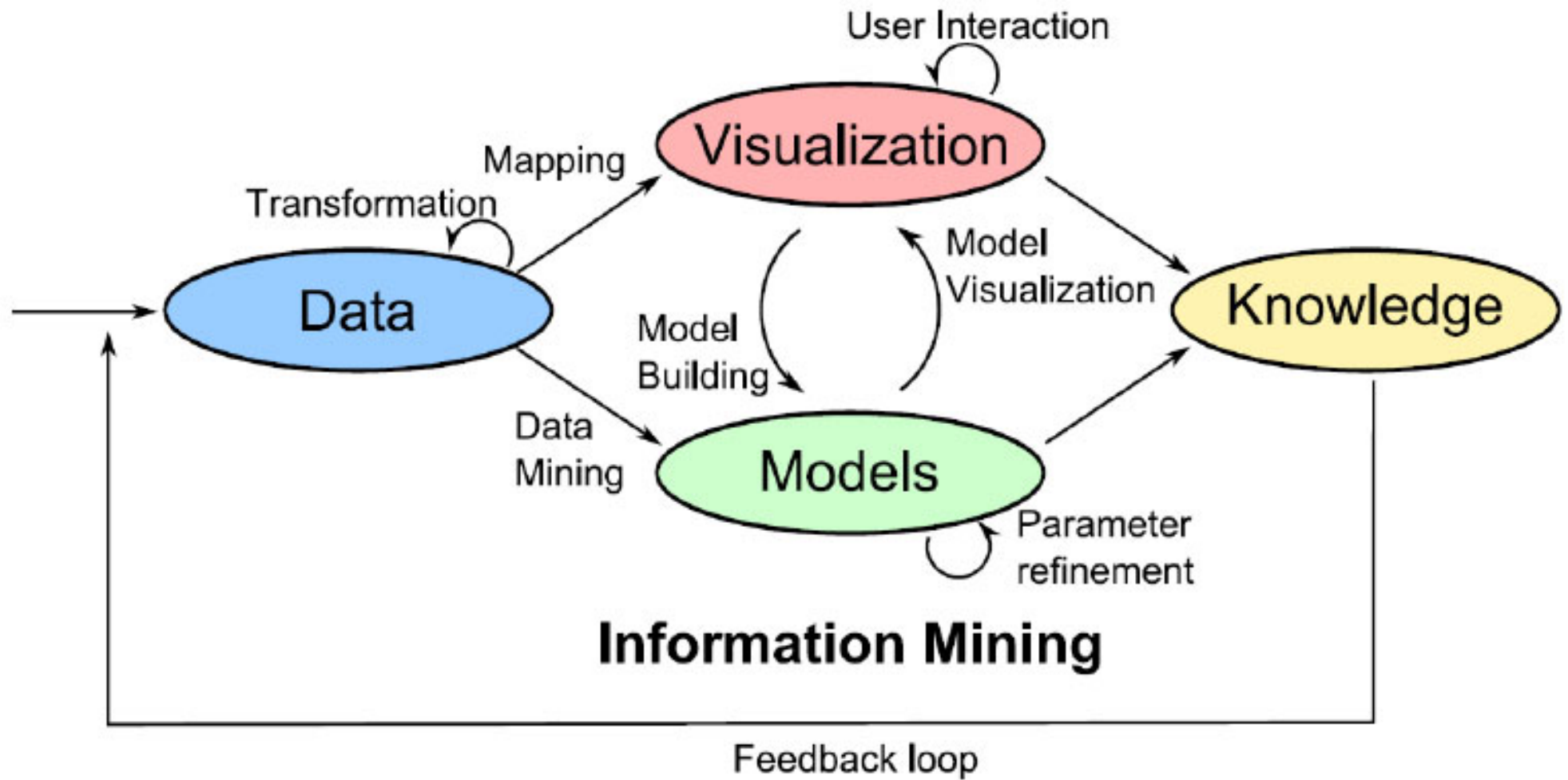

Visual Analytics – Process

[Keim, et al., 2008]

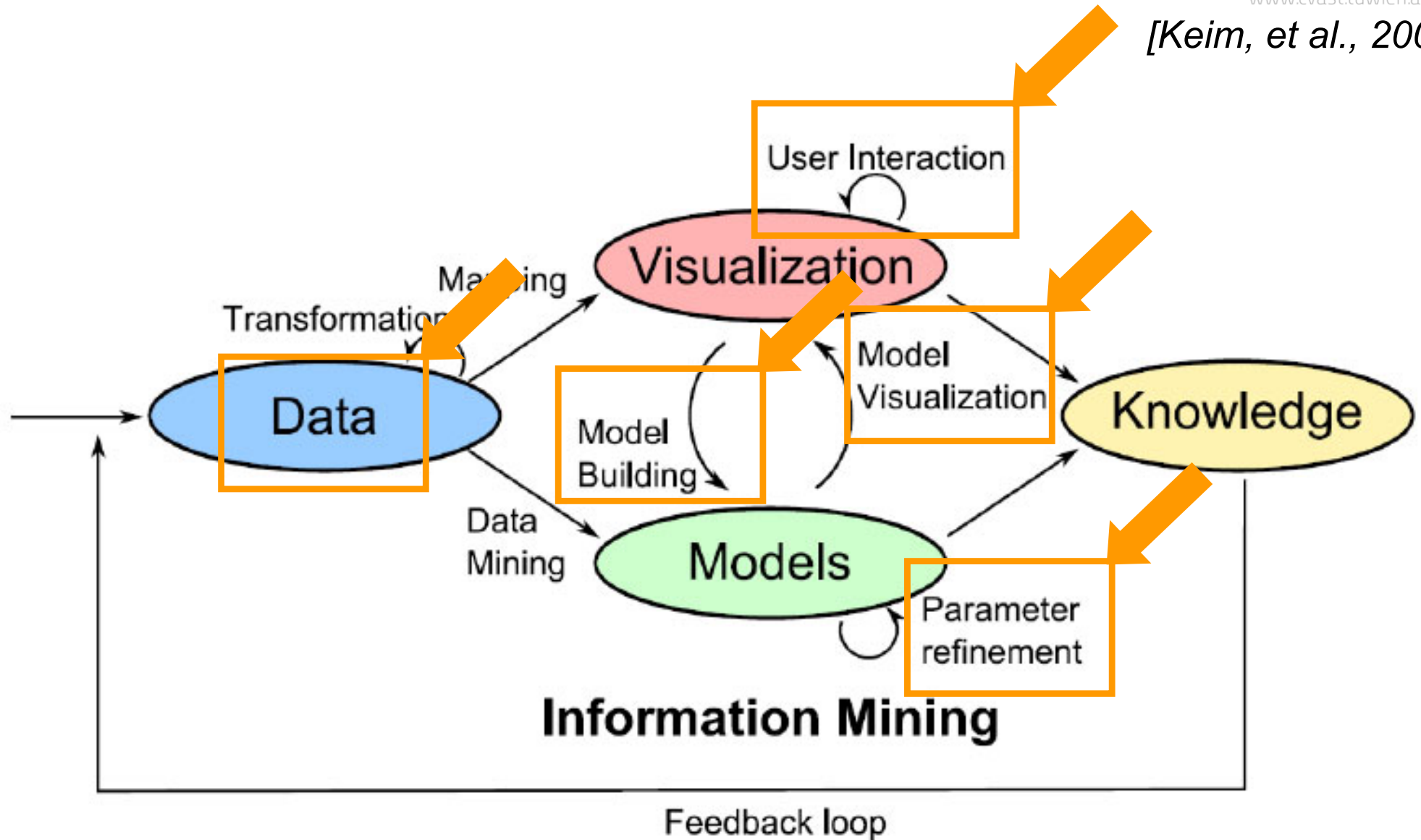

Background ::: Visualization Models

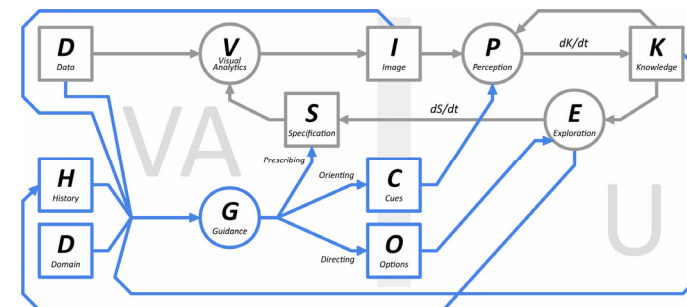
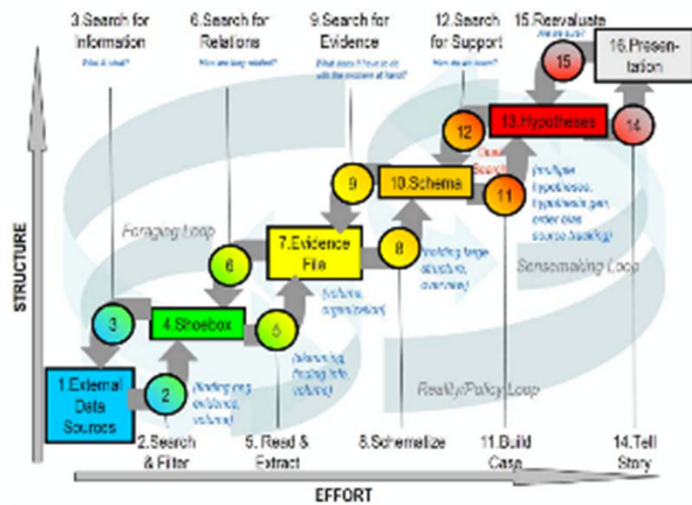
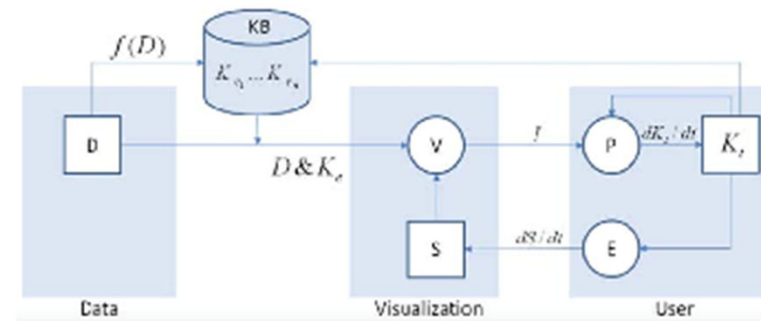
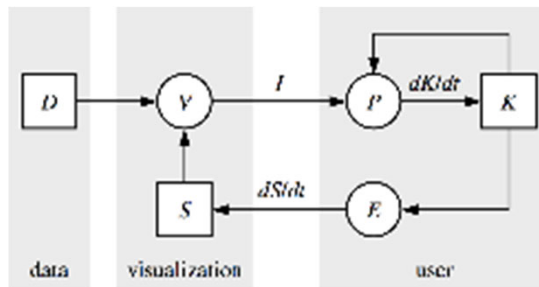

User-Centered Design

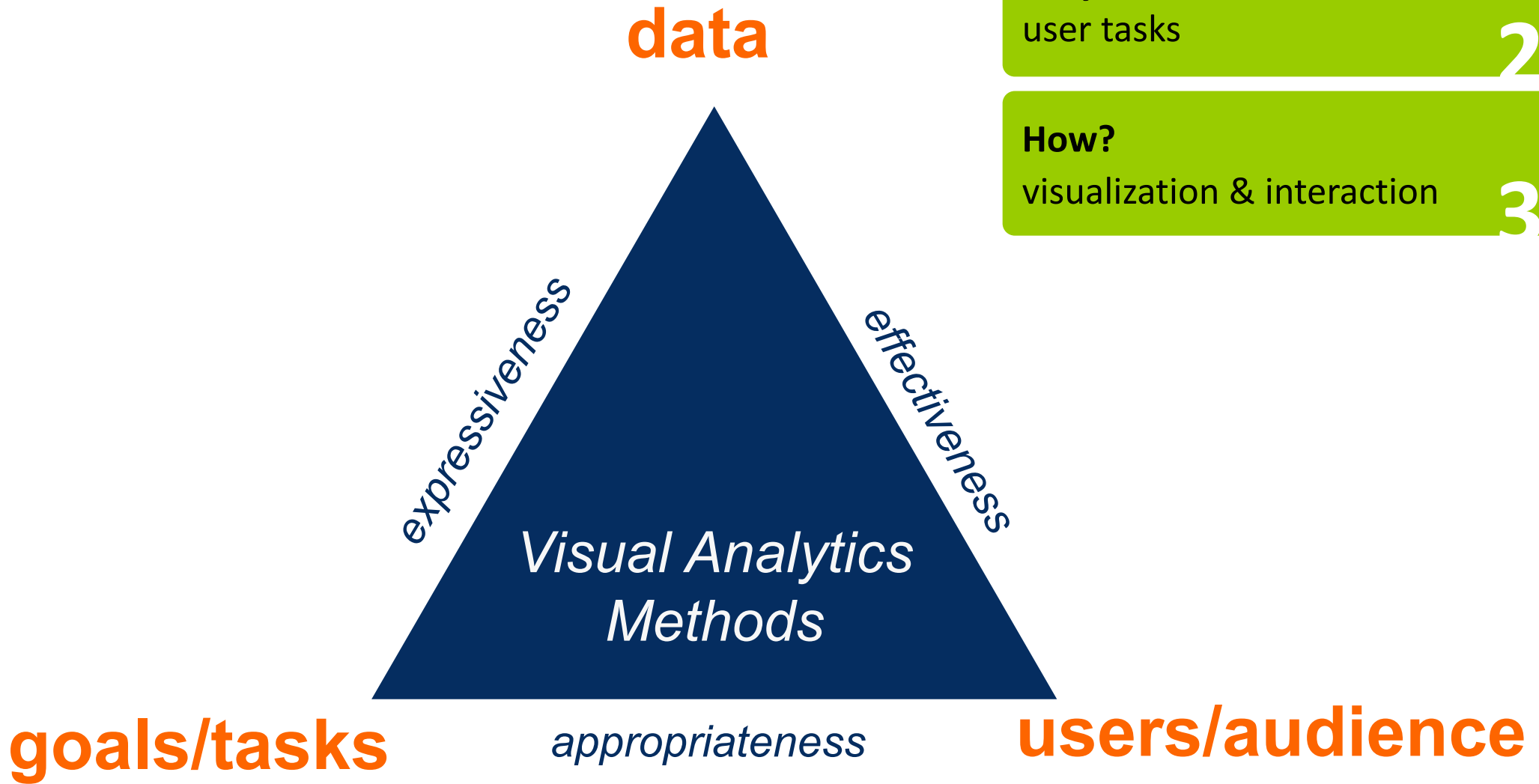

Principles of Mixed-Initiative User Interfaces

Eric Horvitz

Microsoft Research
Redmond, WA 98025 USA
+1 425 936 2127
horvitz@microsoft.com

A mixed-initiative process is an approach where both humans/users and systems can “take the initiative” and both contribute to the process.

ABSTRACT

Recent debate has centered on the relative promise of focusing user-interface research on developing new metaphors and tools that enhance users' abilities to directly manipulate objects *versus* directing effort toward developing interface agents that provide automation. In this paper, we review principles that show promise for allowing engineers to enhance human-computer interaction through an elegant coupling of automated services with direct manipulation. Key ideas will be highlighted in terms of the LookOut system for scheduling and meeting management.

Keywords

Intelligent agents, direct manipulation, user modeling, probability, decision theory, UI design

INTRODUCTION

There has been debate among researchers about where great opportunities lay for innovating in the realm of human-computer interaction [10]. One group of researchers has expressed enthusiasm for the development and application of new kinds of automated services, often referred to as interface “agents.” The efforts of this group center on building machinery for sensing a user's activity and taking automated actions [4,5,6,8,9]. Other researchers have suggested that effort focused on automation might be better expended on exploring new kinds of metaphors and conventions that enhance a user's ability to *directly manipulate* interfaces to access information and invoke services [1,13]. Innovations on both fronts have been fast paced. However, there has been a tendency for a divergence of interests and methodologies versus focused attempts to leverage innovations in both arenas.

We have pursued principles that provide a foundation for integrating research in direct manipulation with work on interface agents. Our goal is to avoid focusing solely on one tack or the other, but to seek valuable synergies between the two areas of investigation. Surely, we should avoid building complex reasoning machinery to patch fundamentally poor designs and metaphors. Likewise, we

wish to avoid limiting designs for human-computer interaction to direct manipulation when significant power and efficiencies can be gained with automated reasoning. There is great opportunity for designing innovative user interfaces, and new human-computer interaction modalities by considering, from the ground up, designs that take advantage of the power of direct manipulation and potentially valuable automated reasoning [2].

PRINCIPLES FOR MIXED-INITIATIVE UI

Key problems with the use of agents in interfaces include poor guessing about the goals and needs of users, inadequate consideration of the costs and benefits of automated action, poor timing of action, and inadequate attention to opportunities that allow a user to guide the invocation of automated services and to refine potentially suboptimal results of automated analyses. In particular, little effort has been expended on designing for a *mixed-initiative* approach to solving a user's problems—where we assume that intelligent services and users may often collaborate efficiently to achieve the user's goals.

Critical factors for the effective integration of automated services with direct manipulation interfaces include:

- (1) **Developing significant value-added automation.** It is important to provide automated services that provide *genuine value* over solutions attainable with direct manipulation.
- (2) **Considering uncertainty about a user's goals.** Computers are often uncertain about the goals and current the focus of attention of a user. In many cases, systems can benefit by employing machinery for inferring and exploiting the uncertainty about a user's intentions and focus.
- (3) **Considering the status of a user's attention in the timing of services.** The nature and timing of automated services and alerts can be a critical factor in the costs and benefits of actions. Agents should employ models of the attention of users and consider the *costs and*

Mixed-Initiative Process

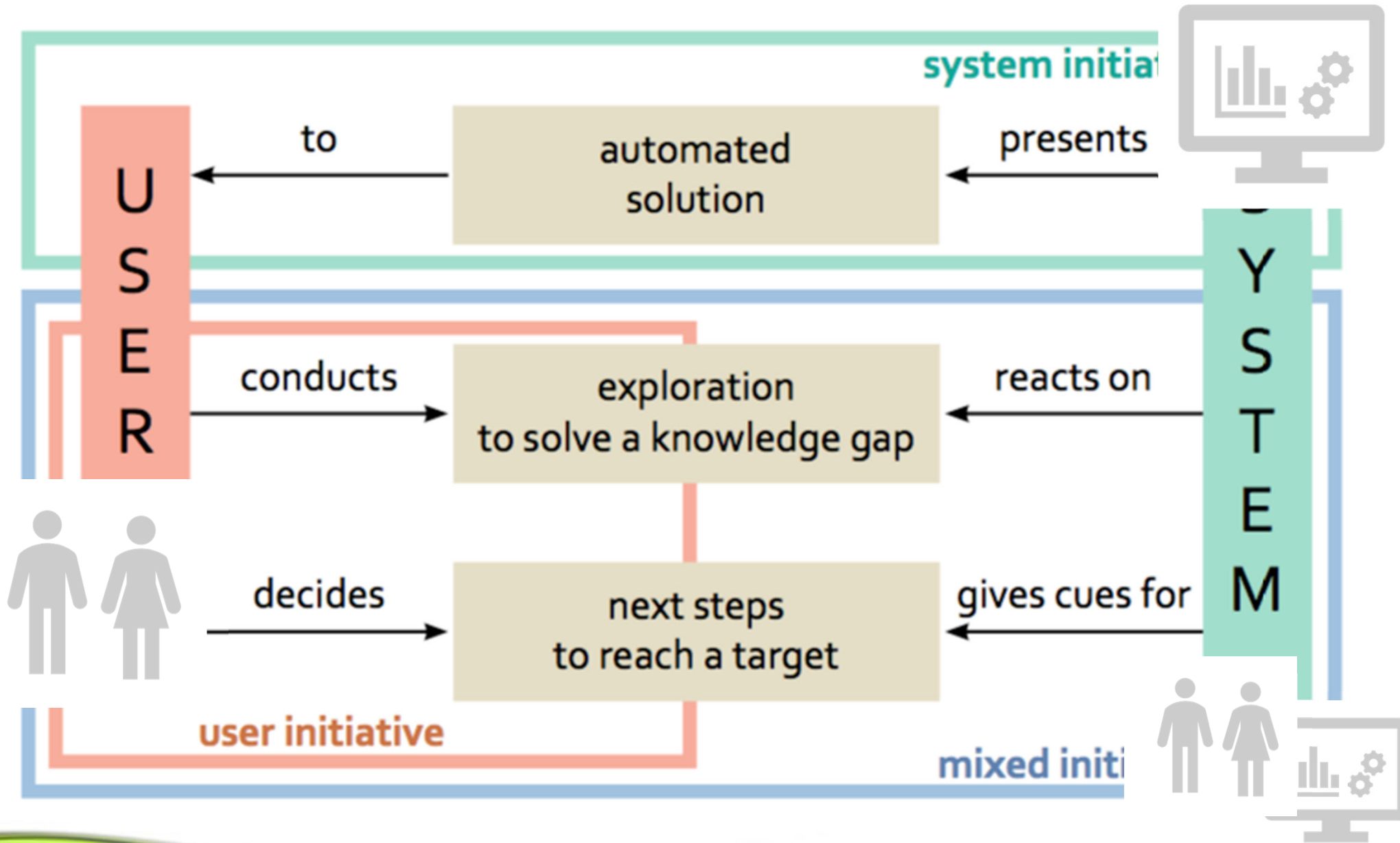

Content

Motivation & Contextualization

Data, Users, & Tasks → Information & Knowledge

Visual Analytics (VA)

Mixed-Initiative Process & Challenges

Guidance-Enriched VA

Models and Concepts

Exempels & Insights

Knowledge-Assisted VA

Models and Concepts

Exempels & Insights

Challenges & Opportunities

Conclusion

GUIDANCE-ENRICHED VA



Characterizing Guidance in Visual Analysis

DAAD
Deutscher Akademischer Austausch Dienst
German Academic Exchange Service

CVAST Laura Bassi Centre of Expertise
Centre for Visual Analytics
Science & Technology

Davide Ceneda, Theresia Gschwandtner, Silvia Miksch  **Informatics**

Hans-Jörg Schulz, Christian Tominski  **Universität Rostock**

Thorsten May  **Fraunhofer IGD**

Marc Streit  **JKU JOHANNES KEPLER UNIVERSITY LINZ**  **Institute of Computer Graphics**

Many VA users are overwhelmed ...

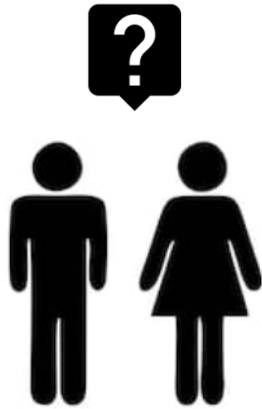

... by the number of visualizations...

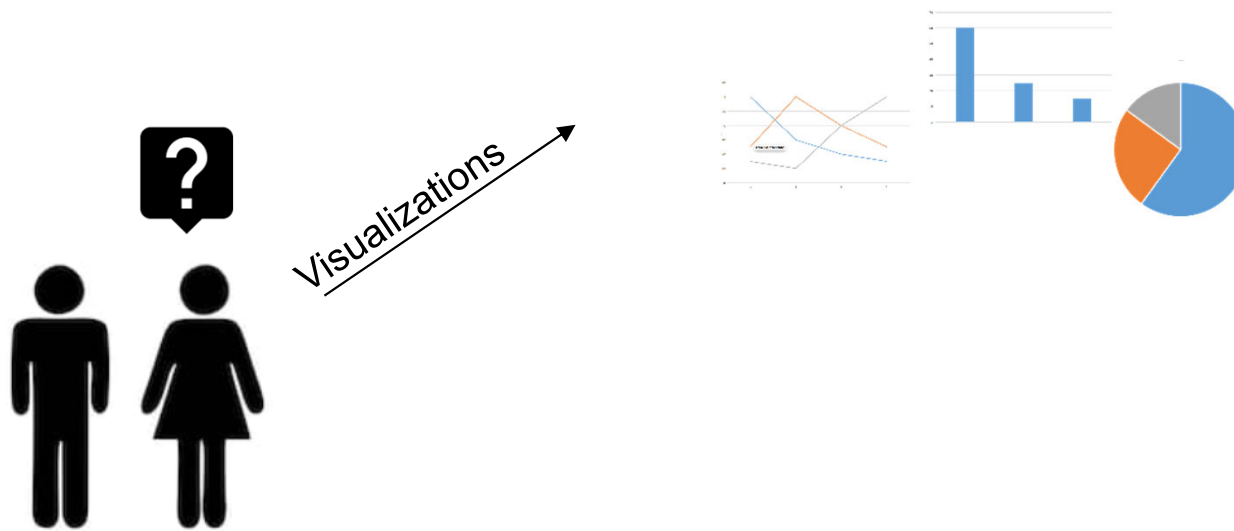

... algorithms ...

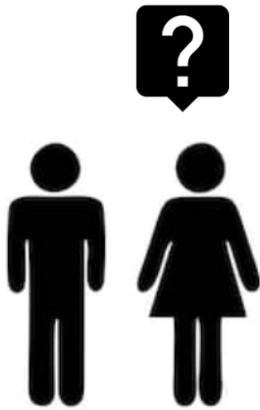

Visualizations

Algorithms

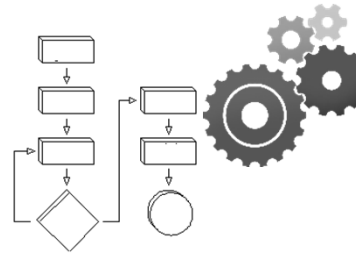
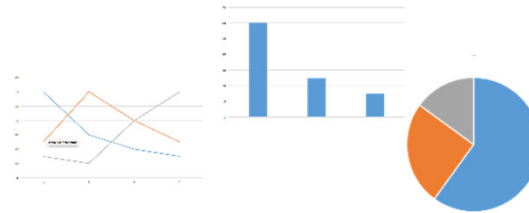

```
1: procedure  
2:    $r \leftarrow a \bmod b$   
3:   while  $r \neq 0$  do  
4:      $a \leftarrow b$   
5:      $b \leftarrow r$   
6:      $r \leftarrow a \bmod b$   
7:   end while  
8:   return  $b$   
9: end procedure
```

... and possible parameters

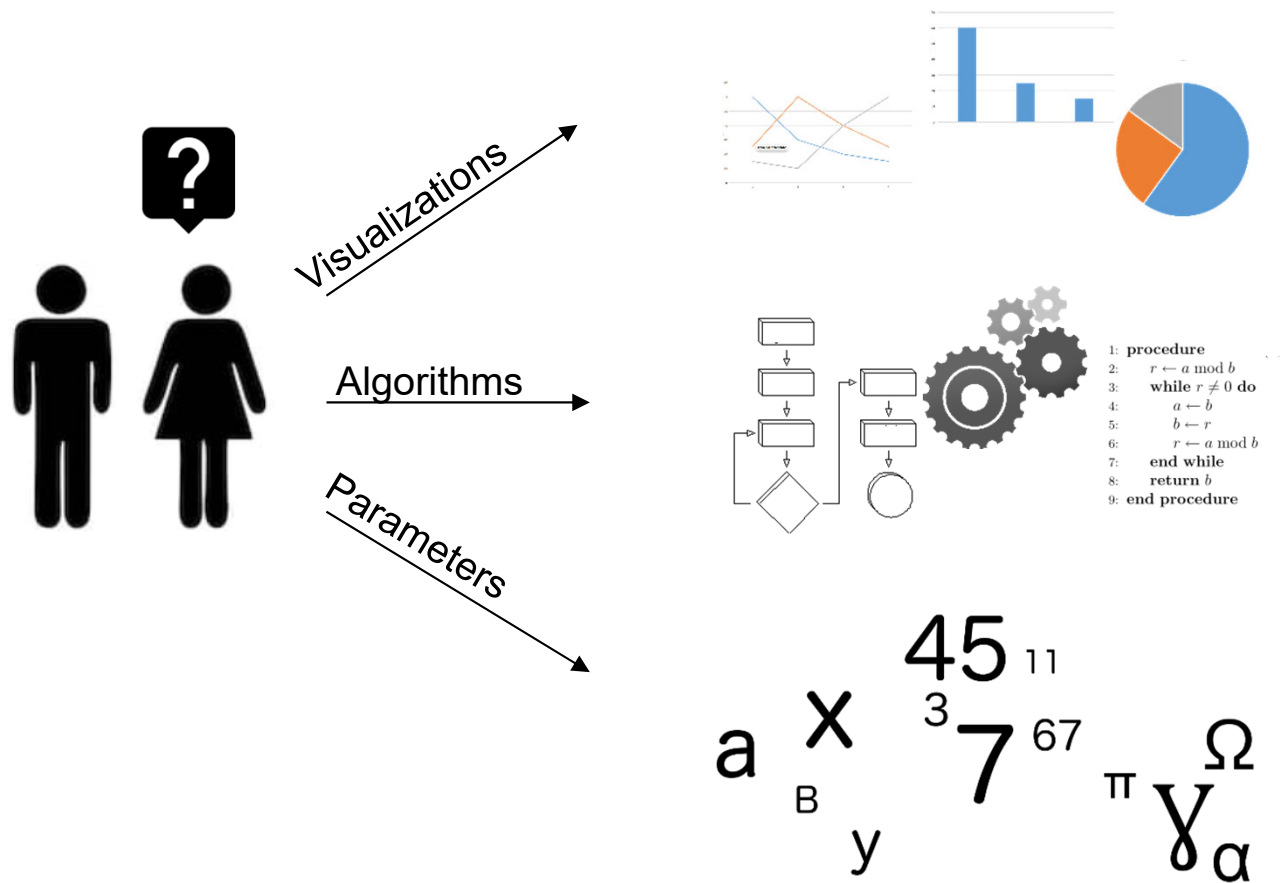

When trying out each and every option
is not possible



We can support users with



Guidance



Guidelines vs. Guidance vs. Onboarding

Guidelines are applied in the development phase of visualizations

Guidance aims to support the user while working with visualizations and keep the analysis loop going

Onboarding helps users to learn, interpret, and use the applied visualization methods correctly

What is Guidance in VA?

The Short Answer

Guidance is a *computer-assisted process* that aims to actively resolve a *knowledge gap* encountered by users during an *interactive* VA session.

Based on [Smith and Mosier 1986] [Engels 1996] [Dix et al. 2004]



Guidance is Mixed Initiative

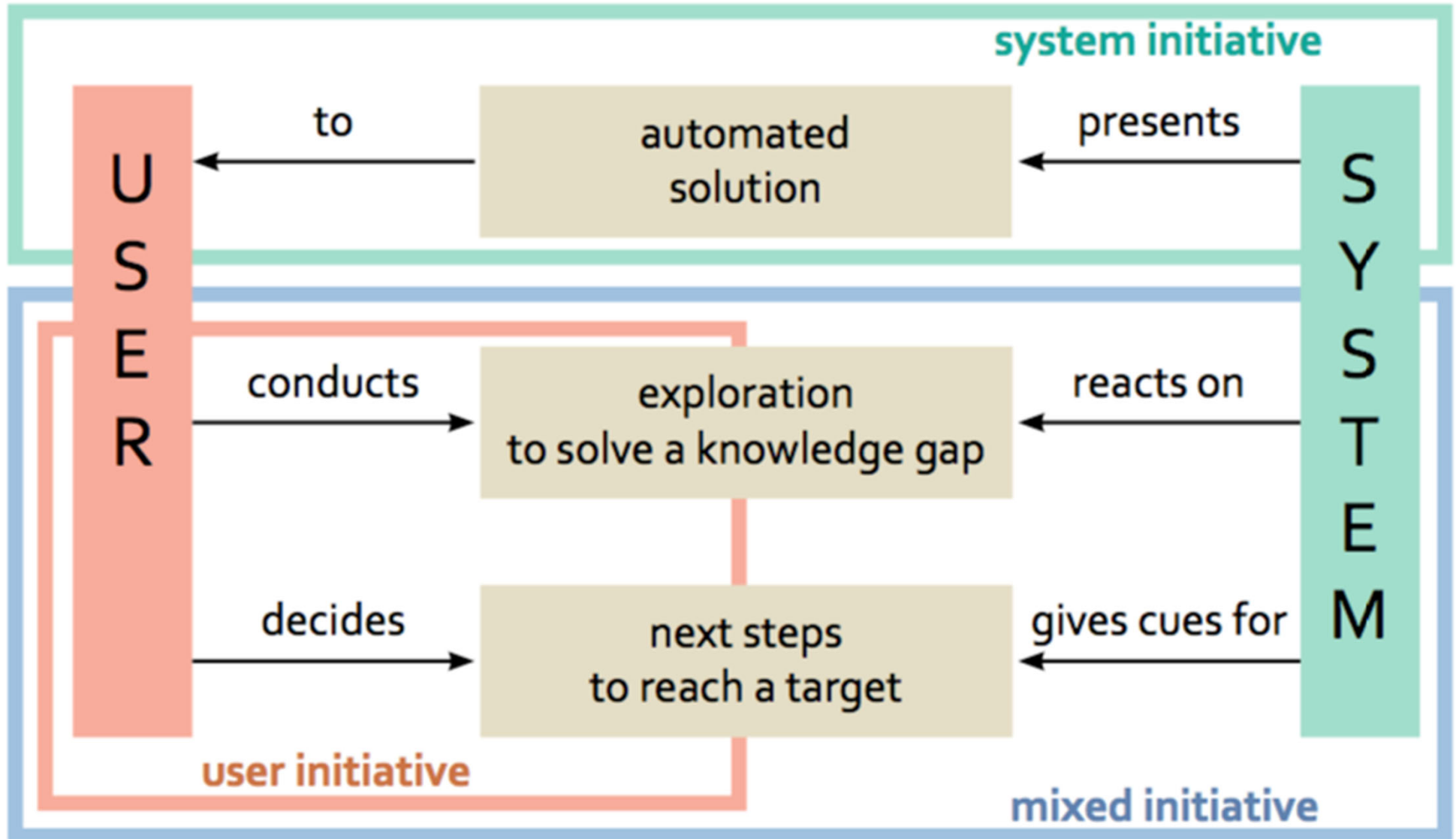

Aspects of Guidance

[Ceneda, et al., 2017]

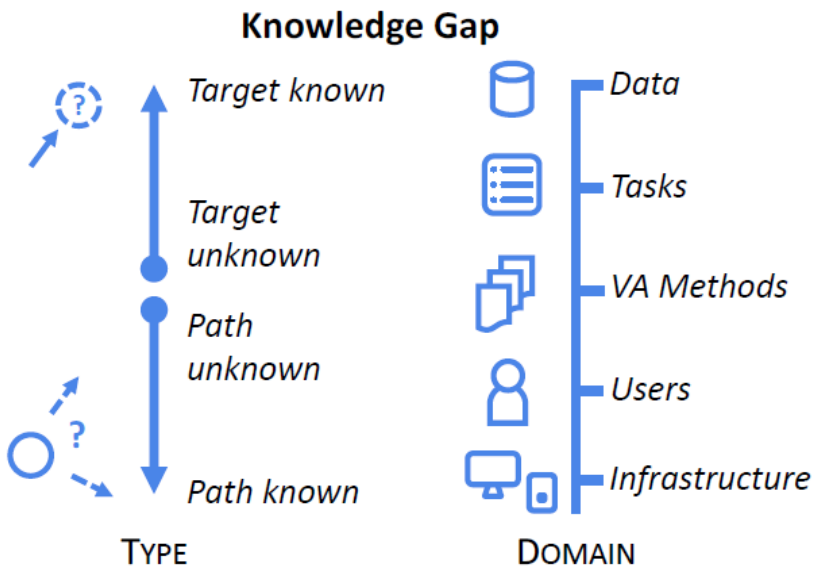

Aspects of Guidance

[Ceneda, et al., 2017]

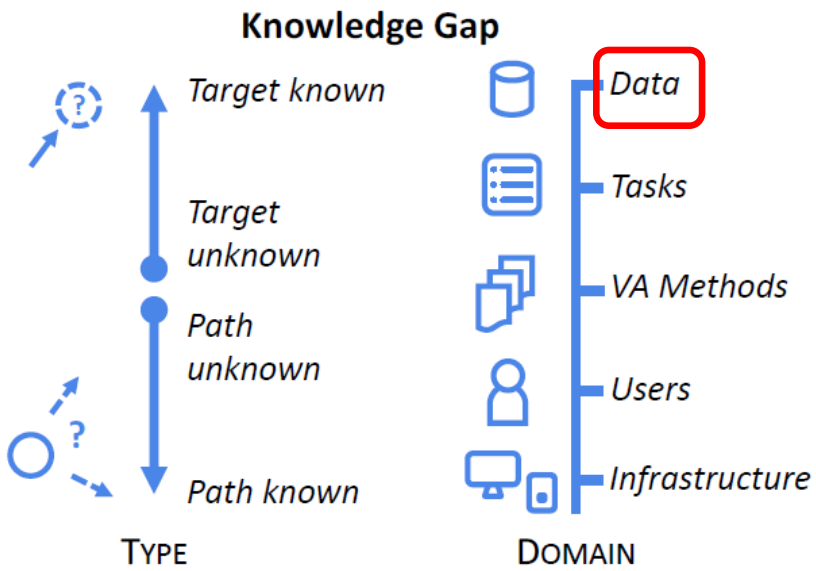

...find interesting data cases

[May et al., 2012]

Aspects of Guidance

[Ceneda, et al., 2017]

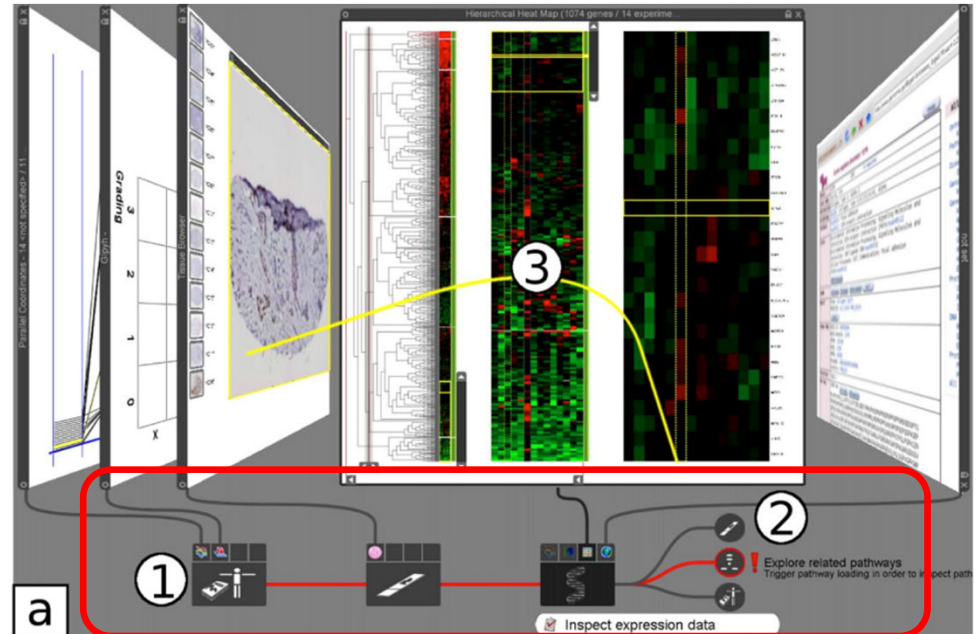
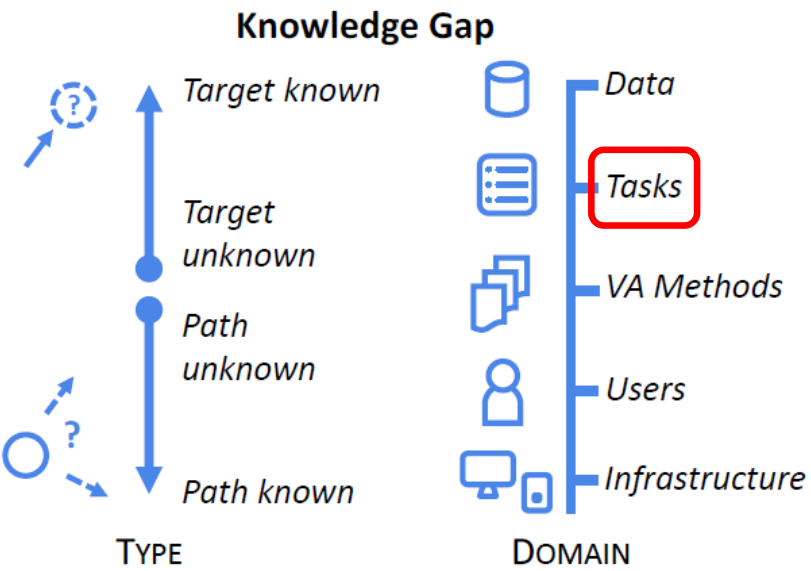

...assist task resolution
[Streit et al.2012]

Aspects of Guidance

[Ceneda, et al., 2017]

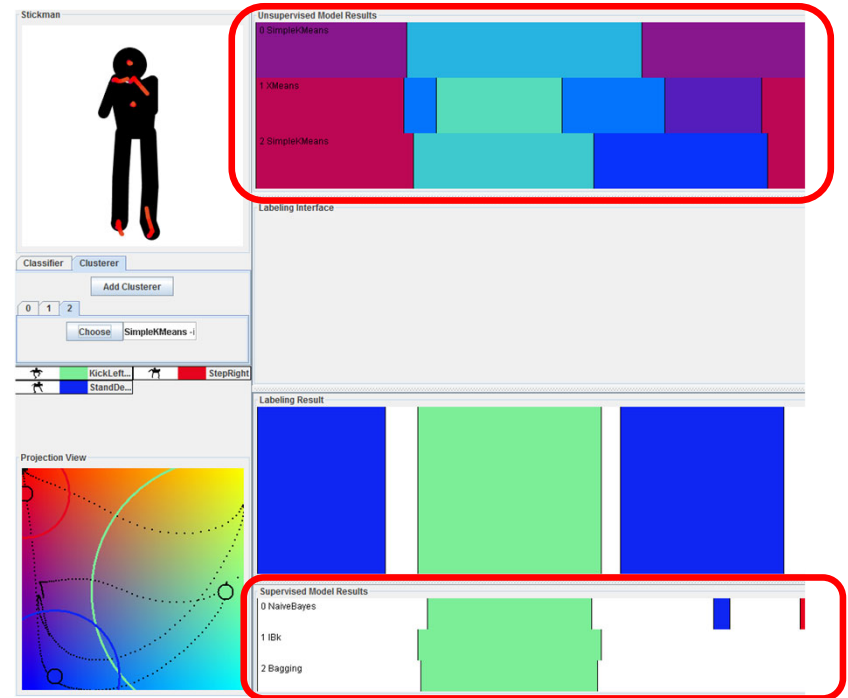
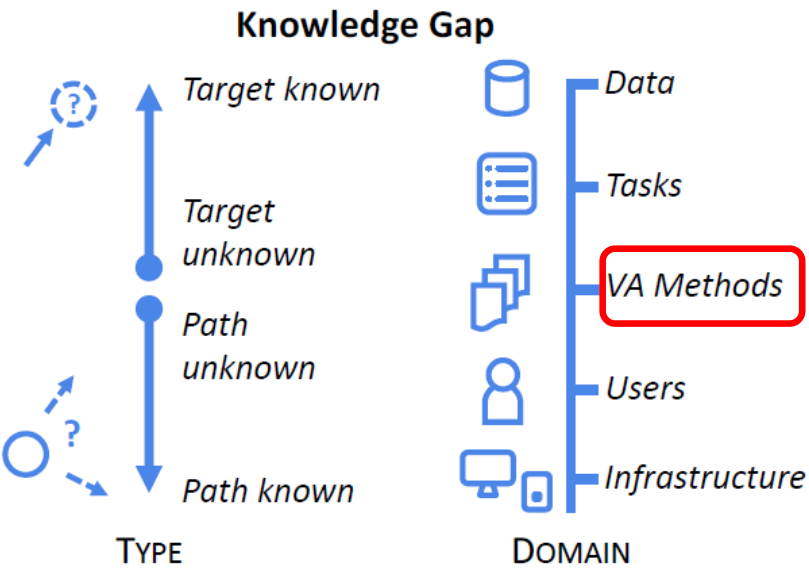

...assist model building

[Bernard et al.2014]

Aspects of Guidance

[Ceneda, et al., 2017]

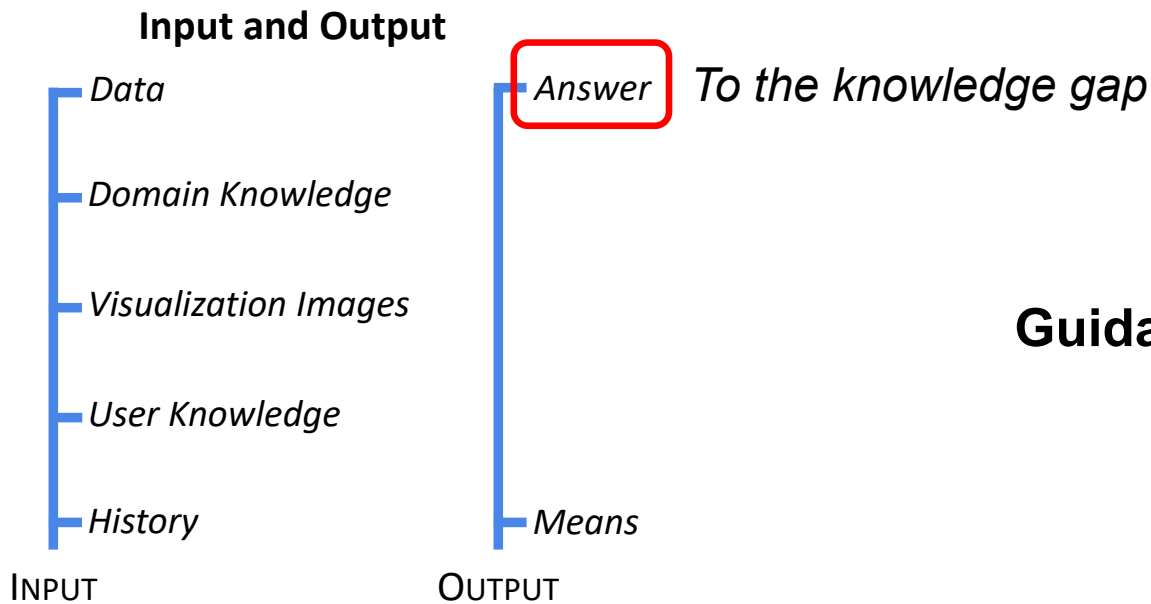

Goal → Solve Knowledge gap

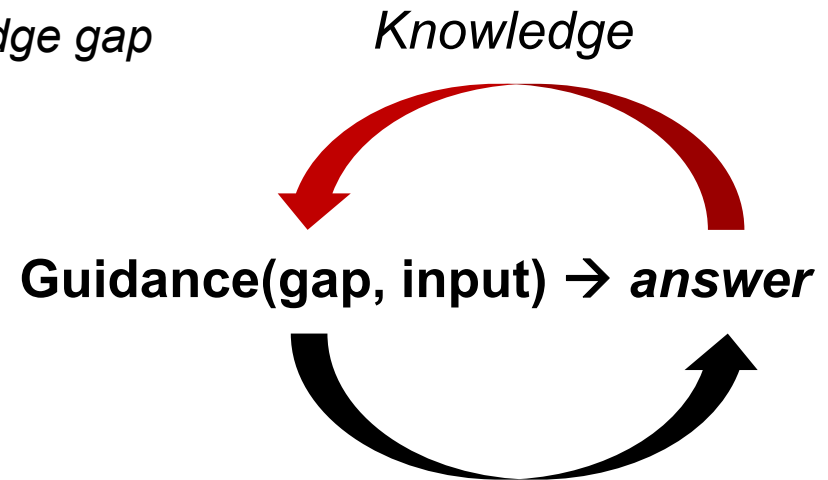

Aspects of Guidance

[Ceneda, et al., 2017]
Highlighting

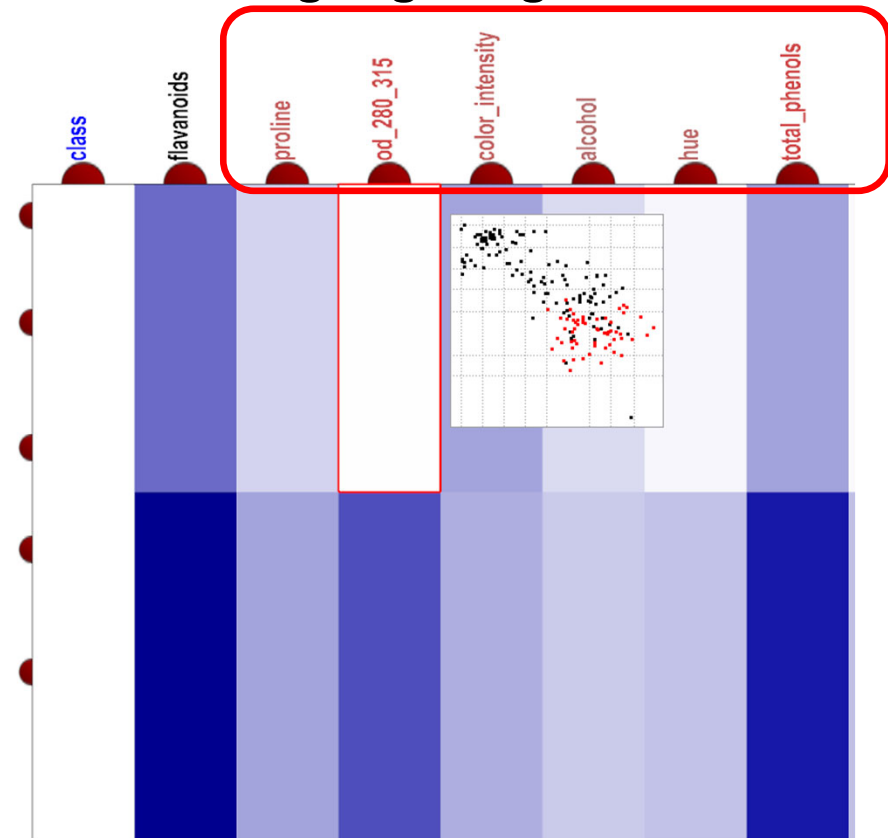
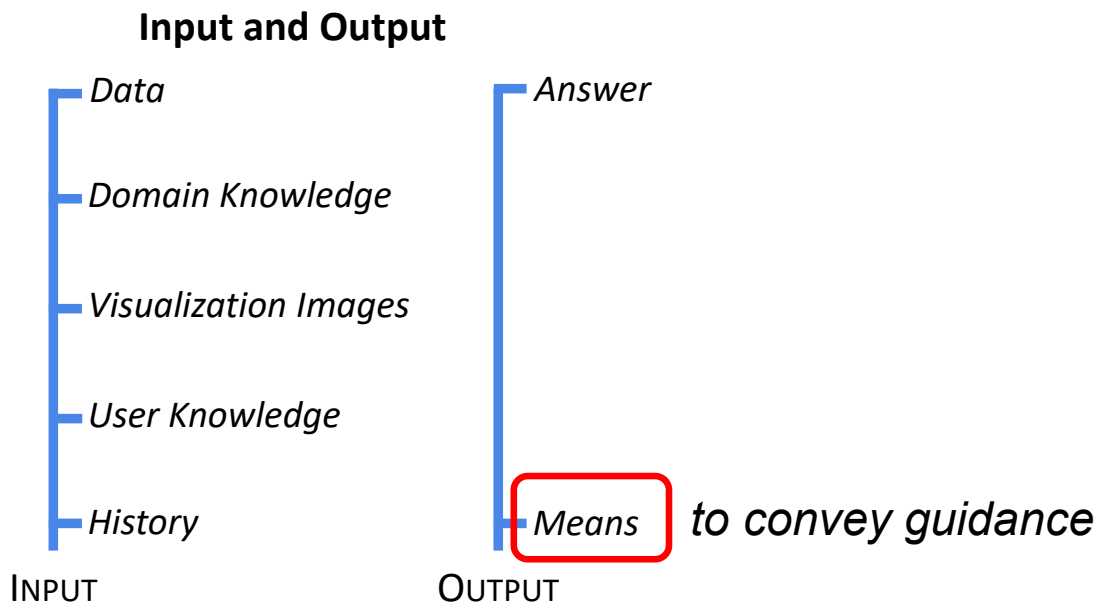

[Ceneda et al.2019]
[May et al., 2011]

Aspects of Guidance

[Ceneda, et al., 2017]

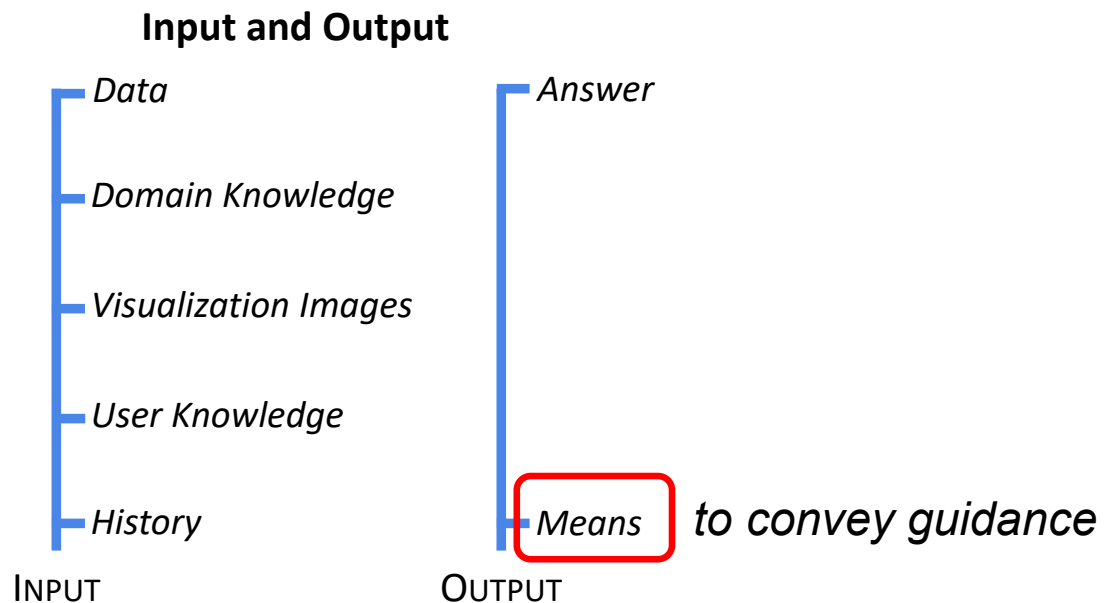

Motion

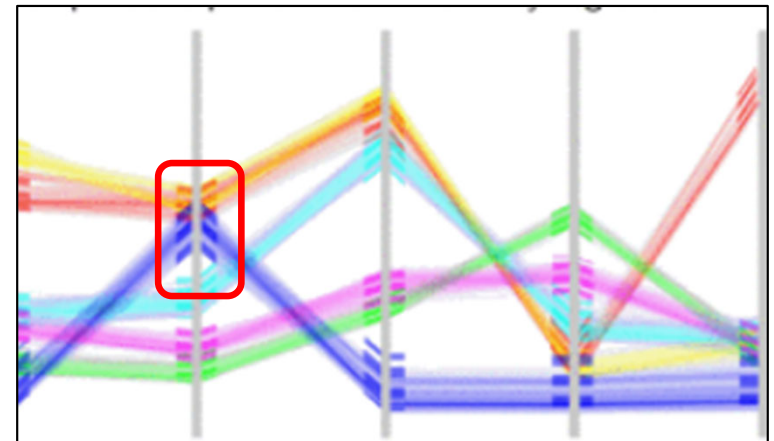

[Ceneda et al. 2019]
[Johansson et al., 2005]

Aspects of Guidance

[Ceneda, et al., 2017]

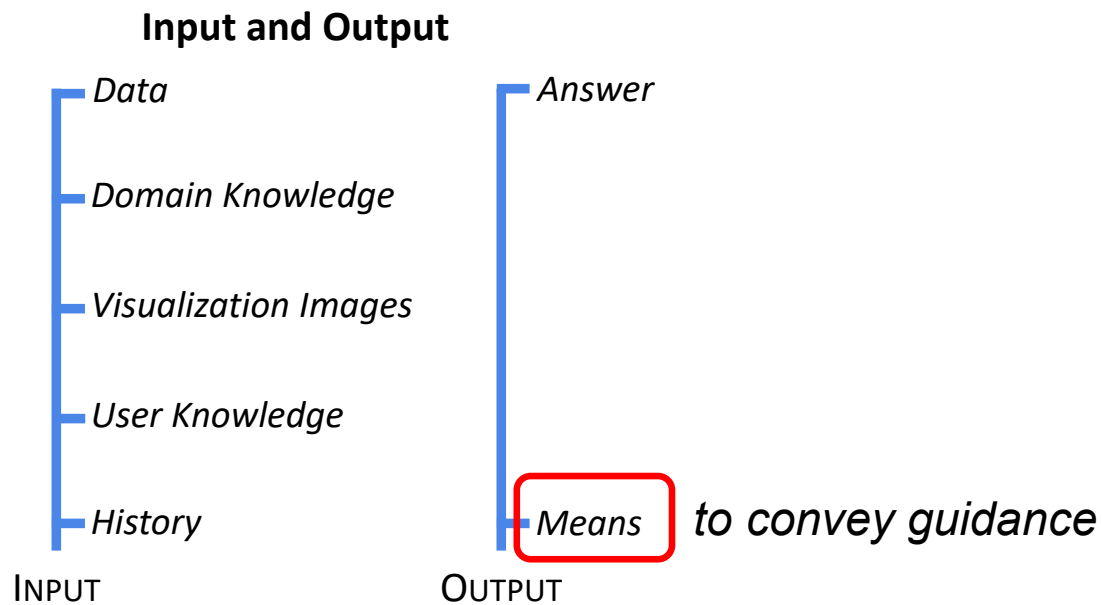

Glyphs/Forms



[Ceneda et al.2019]

[May et al., 2012]

Aspects of Guidance

[Ceneda, et al., 2017]

Knowledge Gap

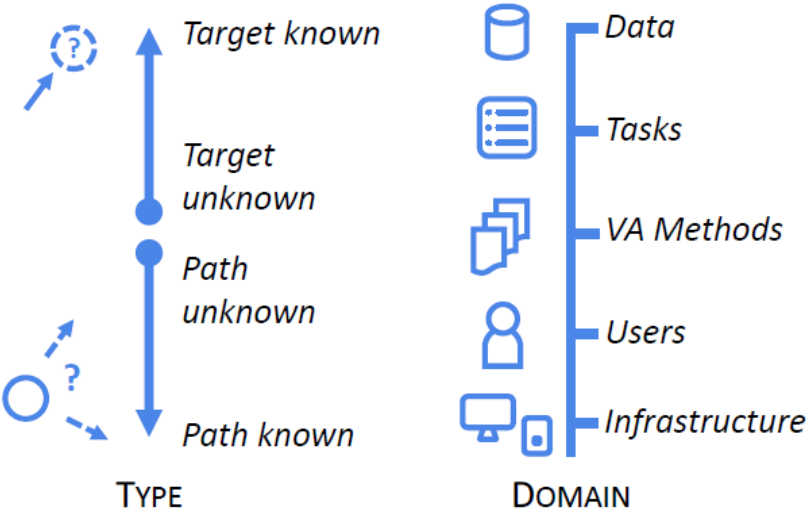

Input and Output

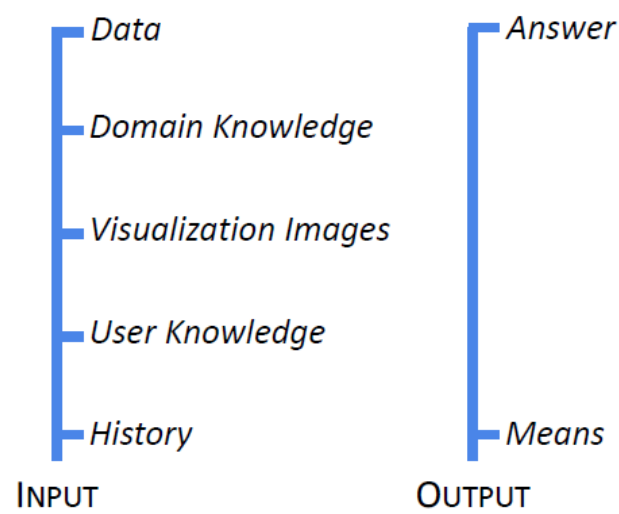

Guidance Degree

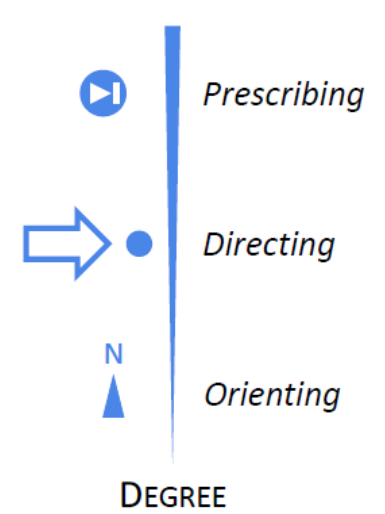

Aspects of Guidance

Some Examples

[Streit et al., 2012]

Guidance Degree

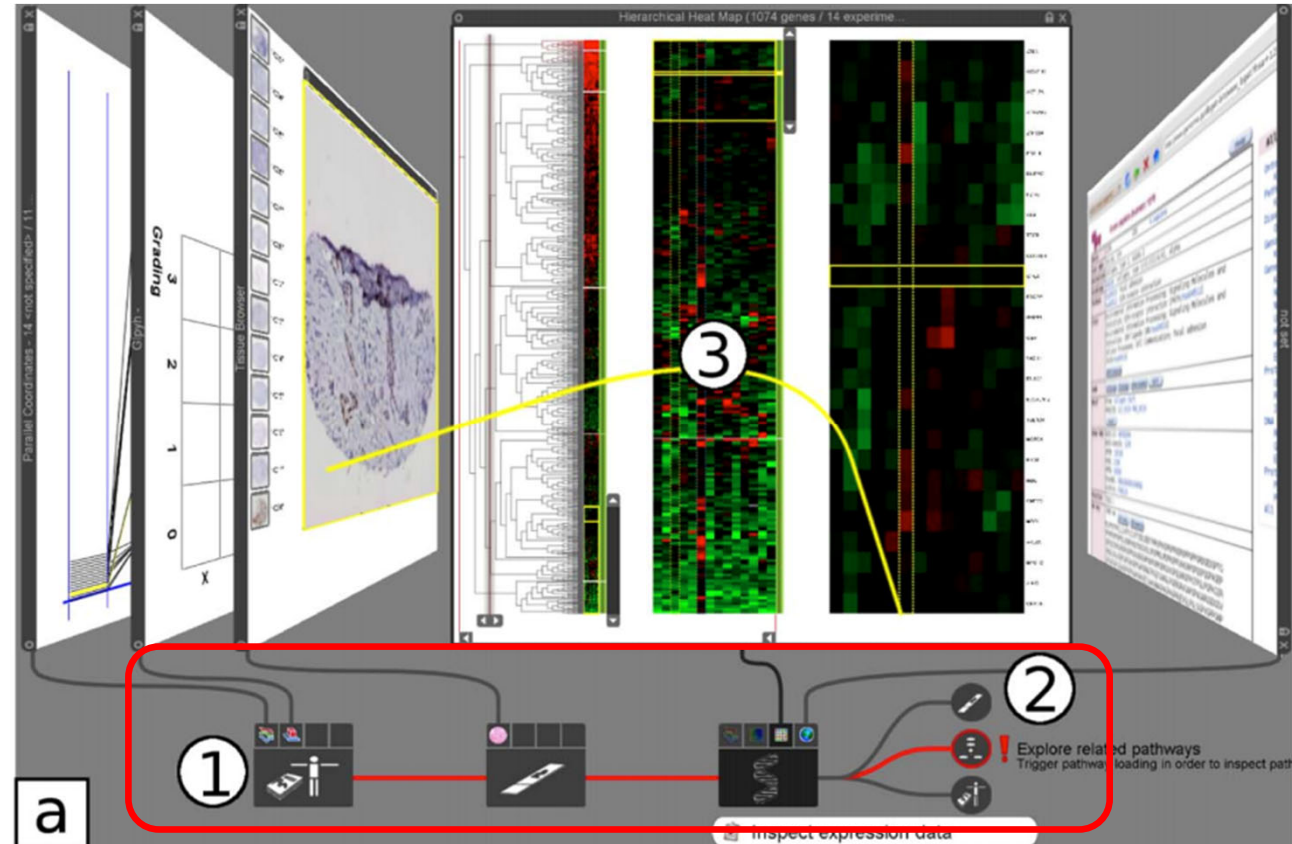
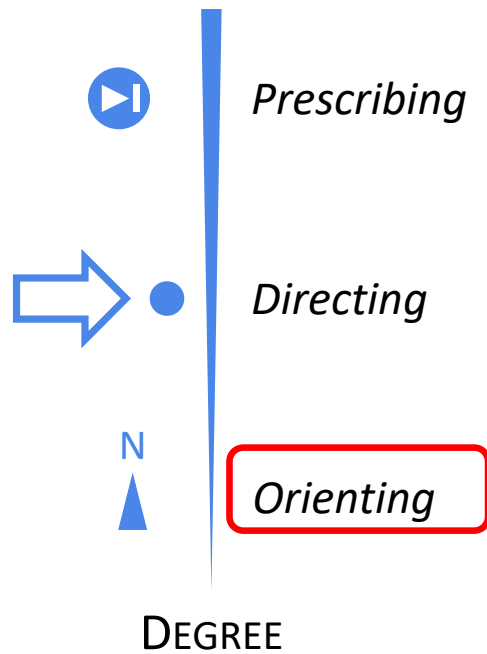

Alternative actions

Aspects of Guidance

Some Examples

Guidance Degree

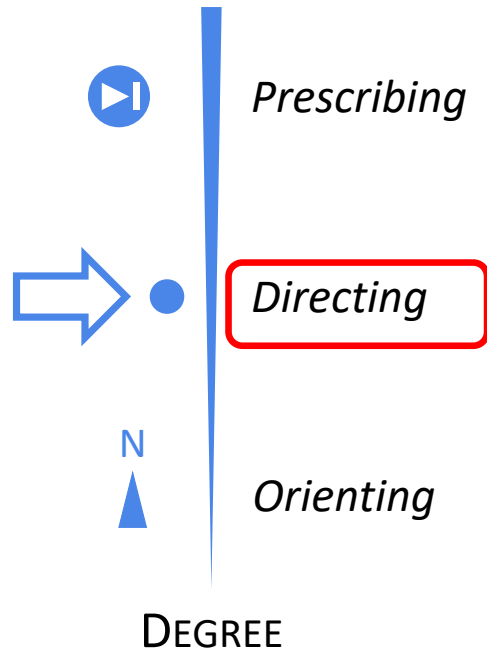

[Wongsuphasawat et al., 2016]

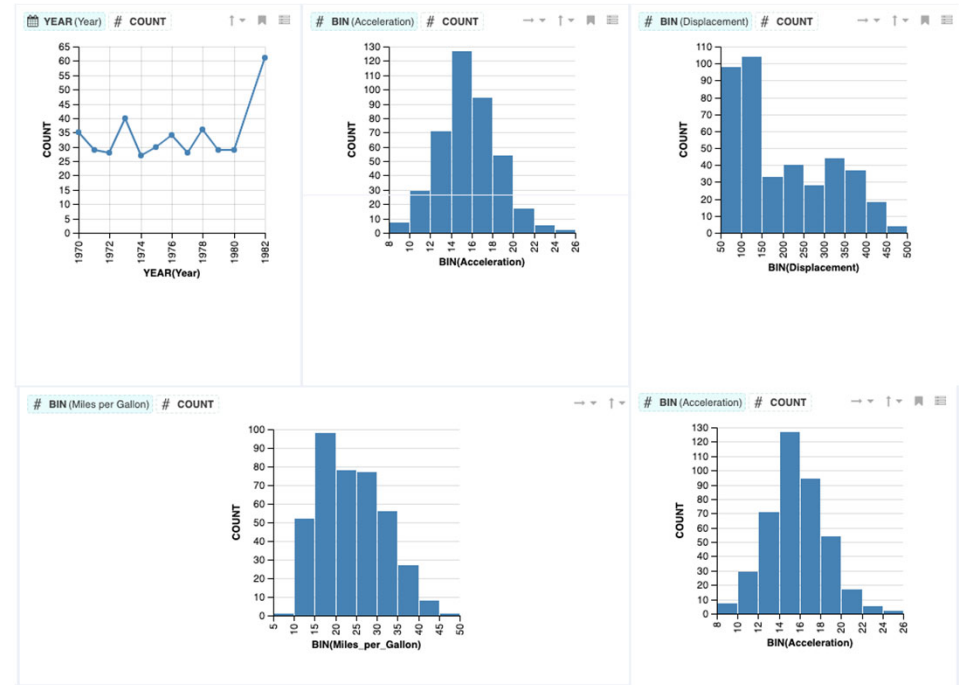

Recommendation of appropriate visualizations

Aspects of Guidance

Some Examples

[Ip et al., 2011]

Guidance Degree

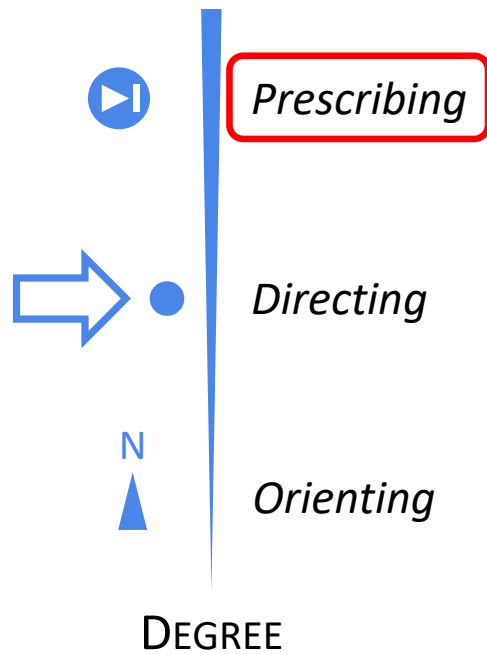

Step-by-step exploration of the most interesting viewpoints

The Computer-Assisted Process

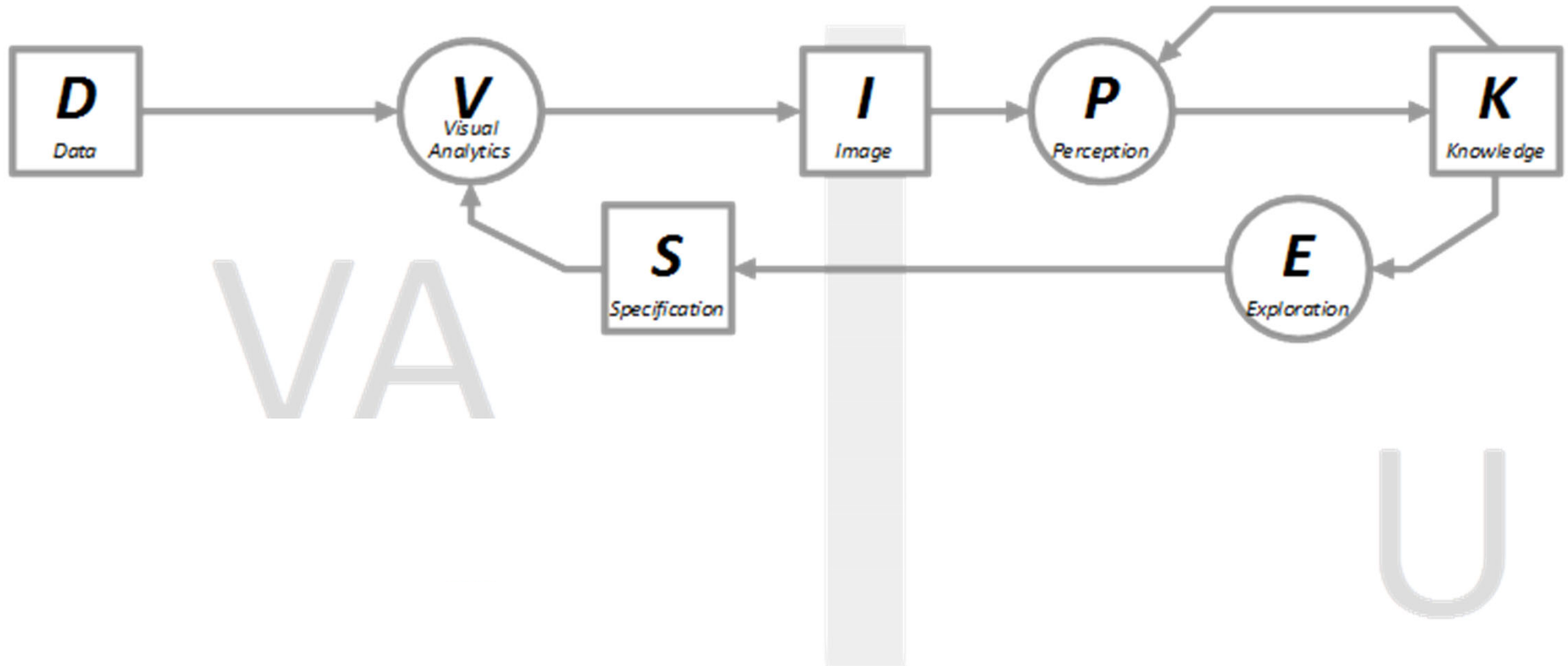

modeled after [van Wijk 2006]

The Computer-Assisted Process

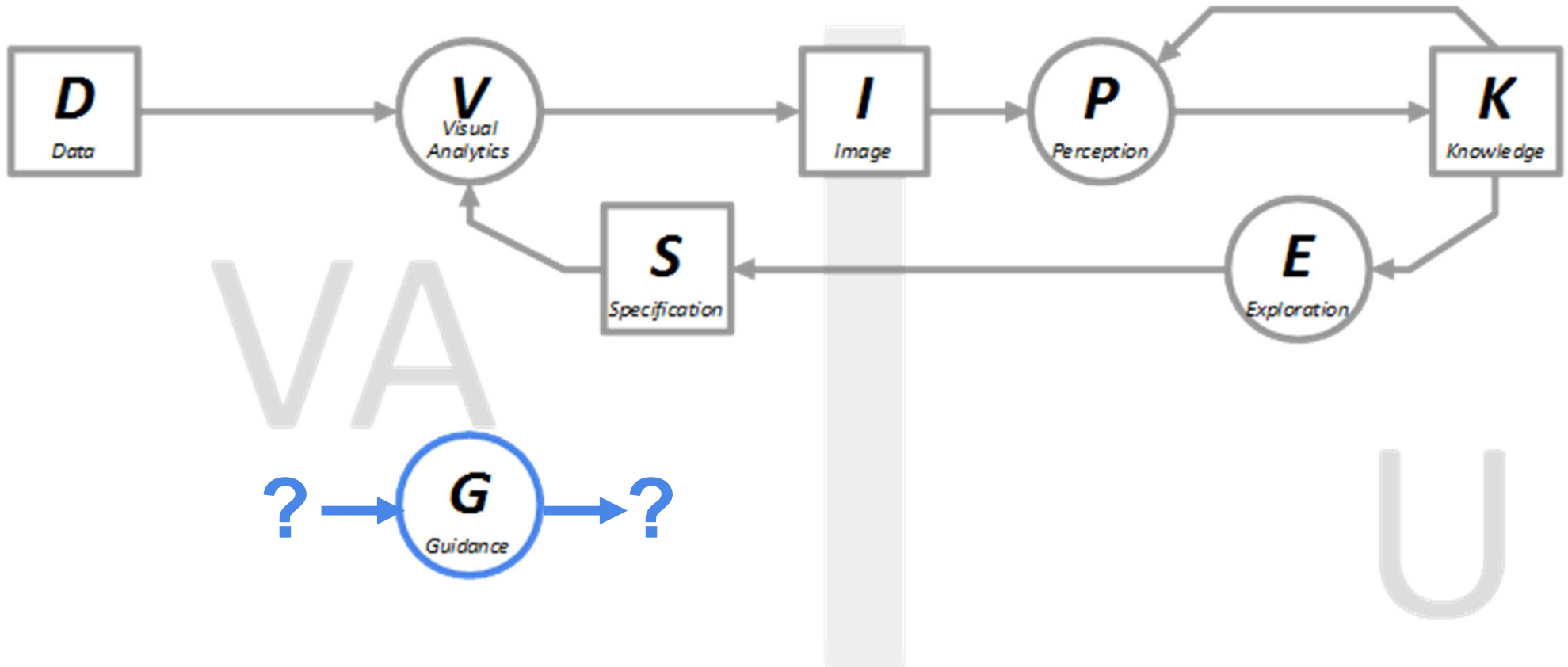

modeled after [van Wijk 2006]

An Example : Guided Visual Exploration of Cyclical Patterns in Time-Series

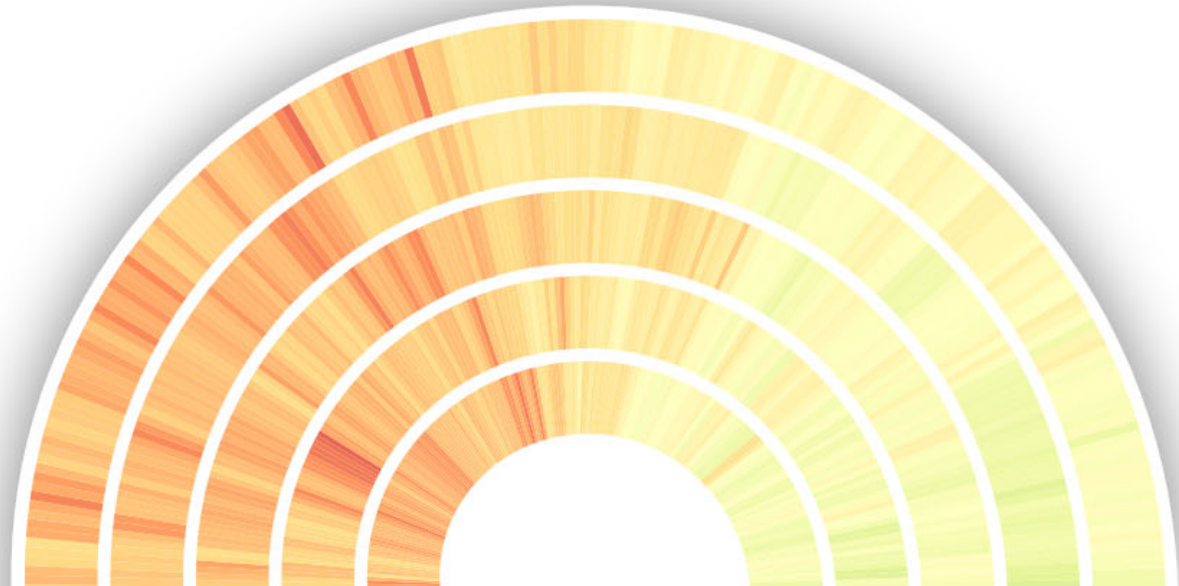
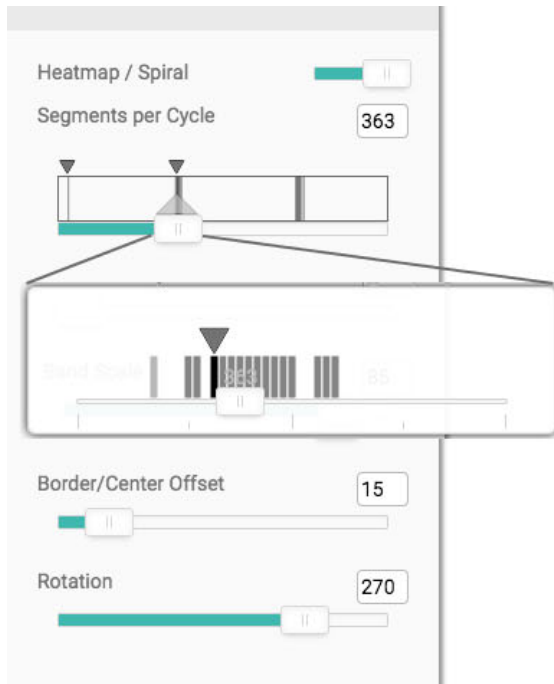

Problem: identify cycles in a time series

Solution (guidance): use statistical methods to show where such cycles can be found in the data

Guided Exploration of Time-Series

Knowledge Gap

Target unknown (parameters)

Data (find cycles)

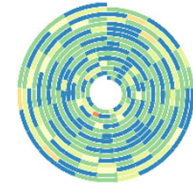
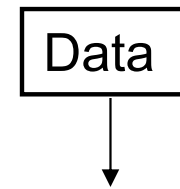

Guided Exploration of Time-Series

Knowledge Gap

Target unknown (parameters)
Data (find cycles)

Input

Data itself
Algorithms
(Fourier Transform/Chi-sq Periodogram)

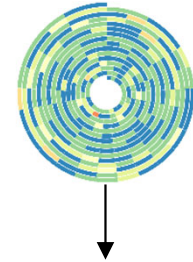
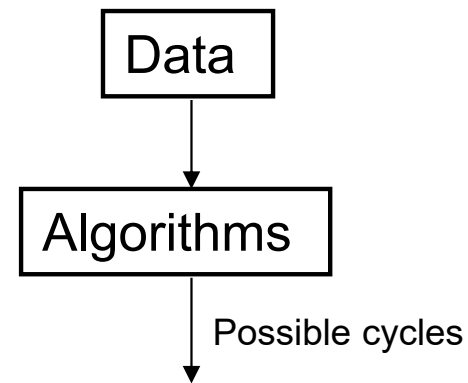

Guided Exploration of Time-Series

Knowledge Gap

Target unknown (parameters)
Data (find cycles)

Input

Data itself
Algorithms
(Fourier Transform/Chi-sq Periodogram)

Output

Indication of possible parameter settings
Encoded in the **spiral** and in the **sliders**

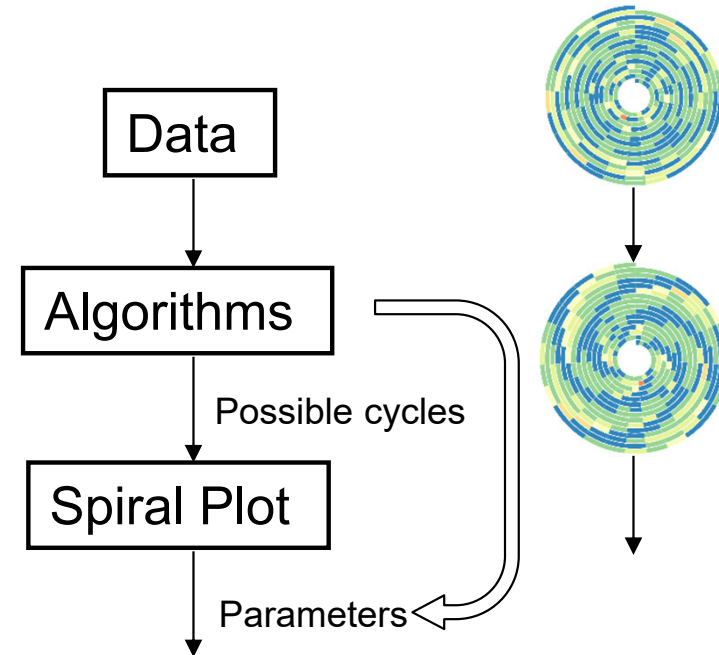

Guided Exploration of Time-Series

Knowledge Gap

Target unknown (parameters)
Data (find cycles)

Input

Data itself
Algorithms
(Fourier Transform/Chi-sq Periodogram)

Output

Indication of possible parameter settings
Encoded in the **spiral** and in the **sliders**

Degree

Orienting guidance

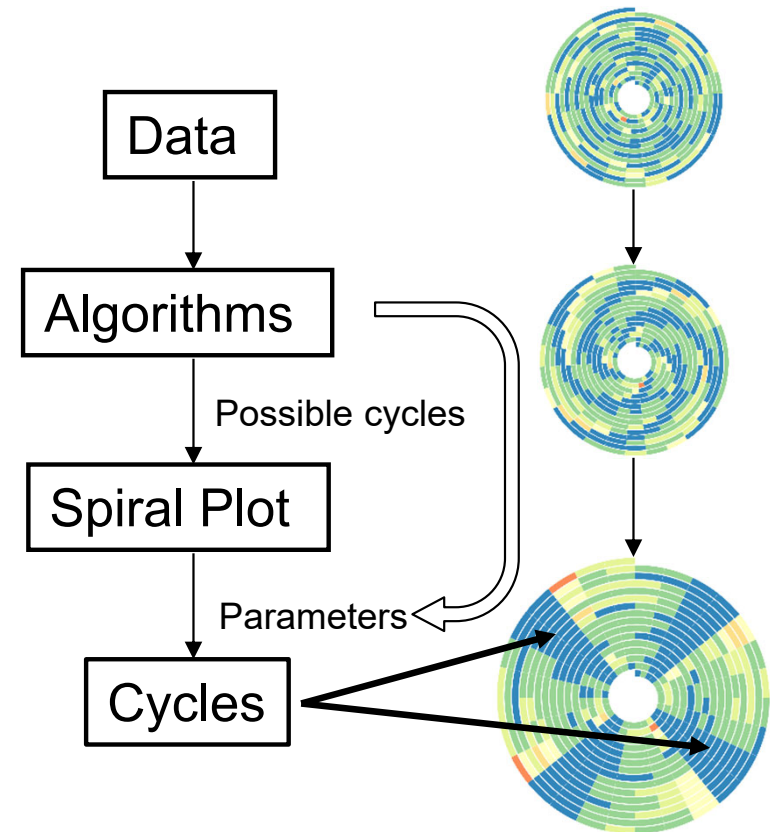

Guidance in Detail

SLIDERS

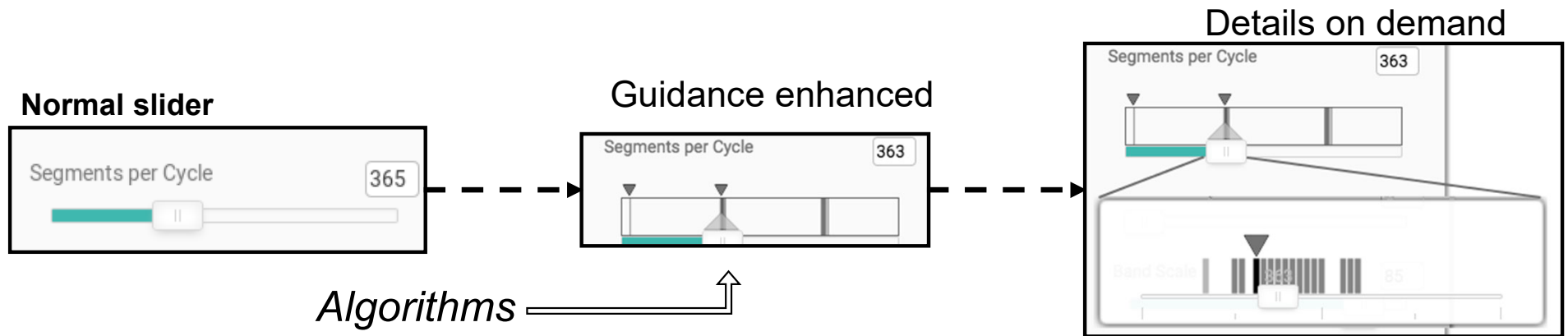

Guidance in Detail

SPIRAL

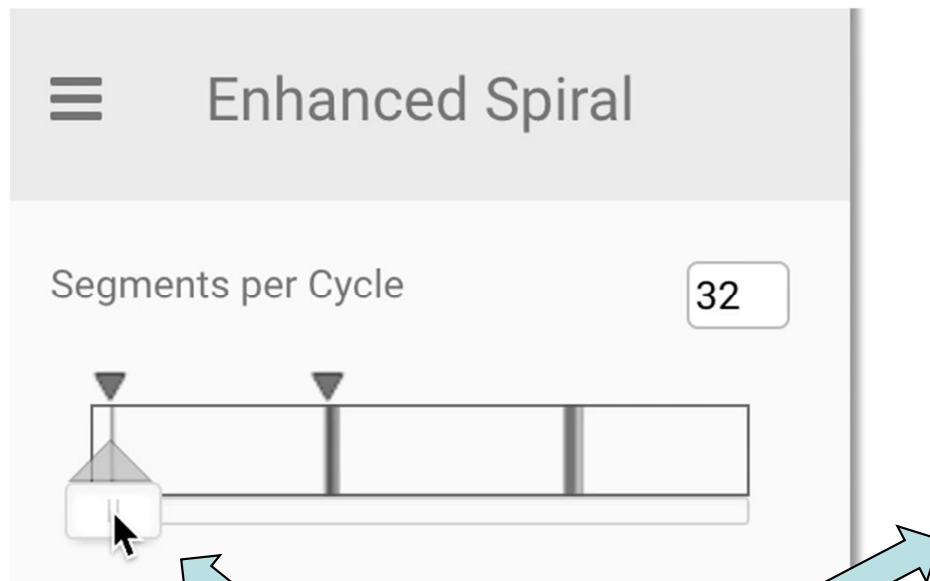

Getting closer to the cycle, a glow appears around the spiral

Enhanced Spiral

Segments per Cycle

Number of Cycles

Delimiter Strength

Band Scale

Border/Center Offset

Rotation

Color Map

Color Legend

Smooth Colors

Reverse Colors

Two-tone Colors

Two-tone Flip

Heatmap / Spiral

Glow

This software builds on [jQuery](#), [Normalize.css](#), [Font Awesome](#), and [chroma.js](#).
© Christian Tominski, 2016-2017

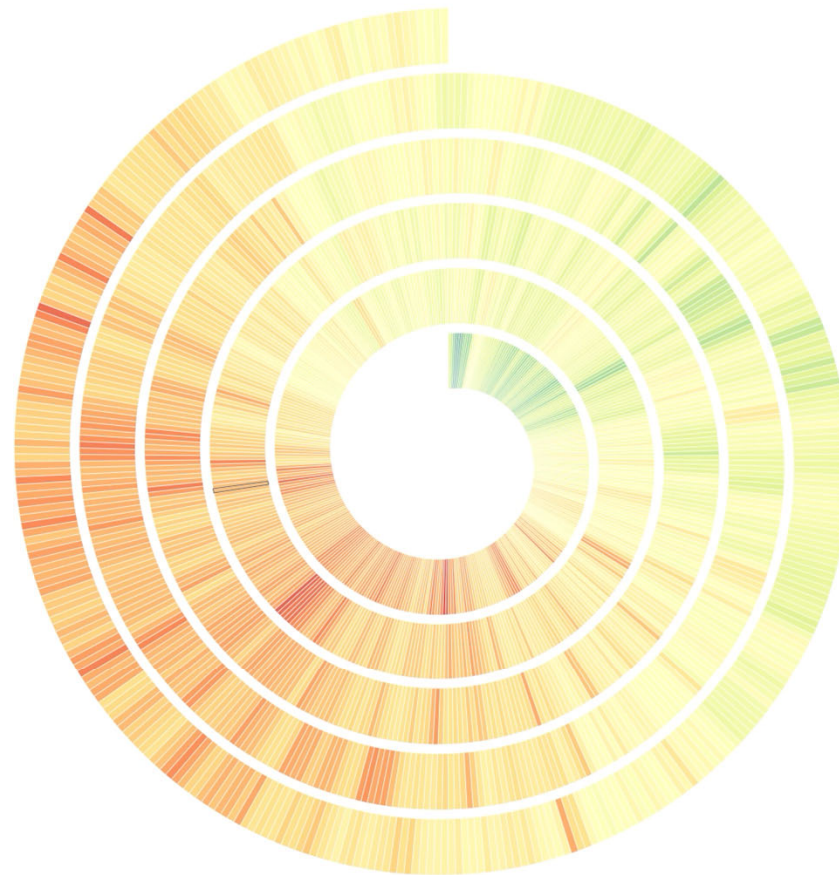

GuidedVA: Guidance-Enriched VA for Temporal Data

DoRIAH: Domain-Adaptive Remote Sensing Image Analysis with Human-in-the-Loop

W|W|T|F



• Scientific partners



• *Computer Vision: Computer Vision Lab, TU Wien*



• *Georeferencing and Photogrammetry: Research Group Photogrammetry, TU Wien*



• *Visual Analytics: Centre for Visual Analytics Science and Technology, TU Wien*

• Business partner



• *Luftbilddatenbank Dr. Carls GmbH*

• Participation in user studies



UXO Detection from Aerial Images



UXOs ... UneXploded Ordnances

UXO Detection from Aerial Images

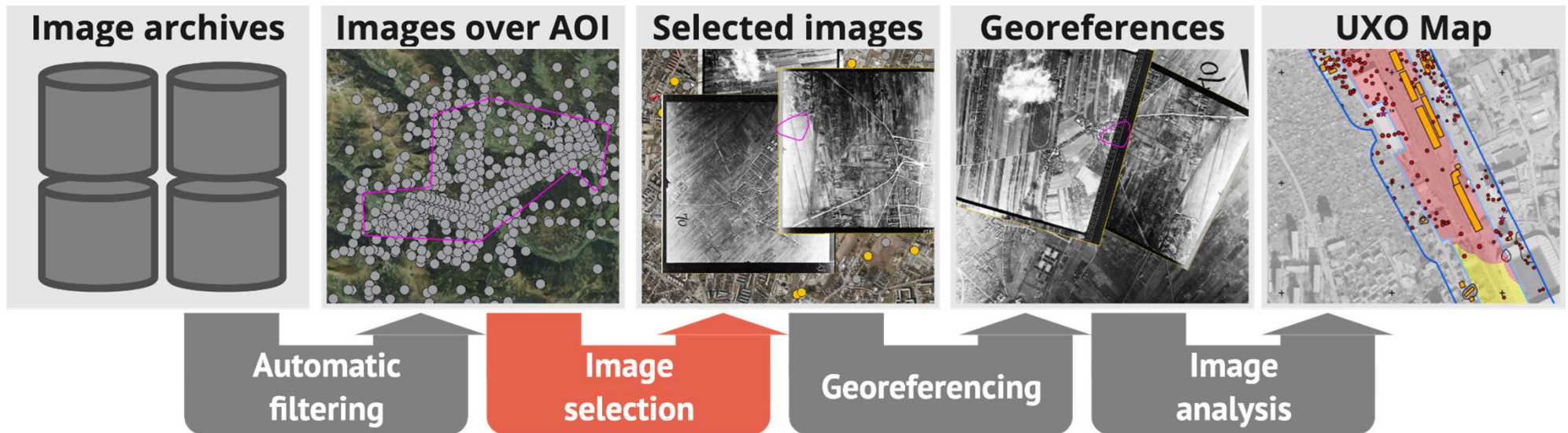

*Guided Visual Analytics for Image Selection
in Time and Space*

Visual Encoding in Time

Images

Flight

Attacks

Timeline

User selection

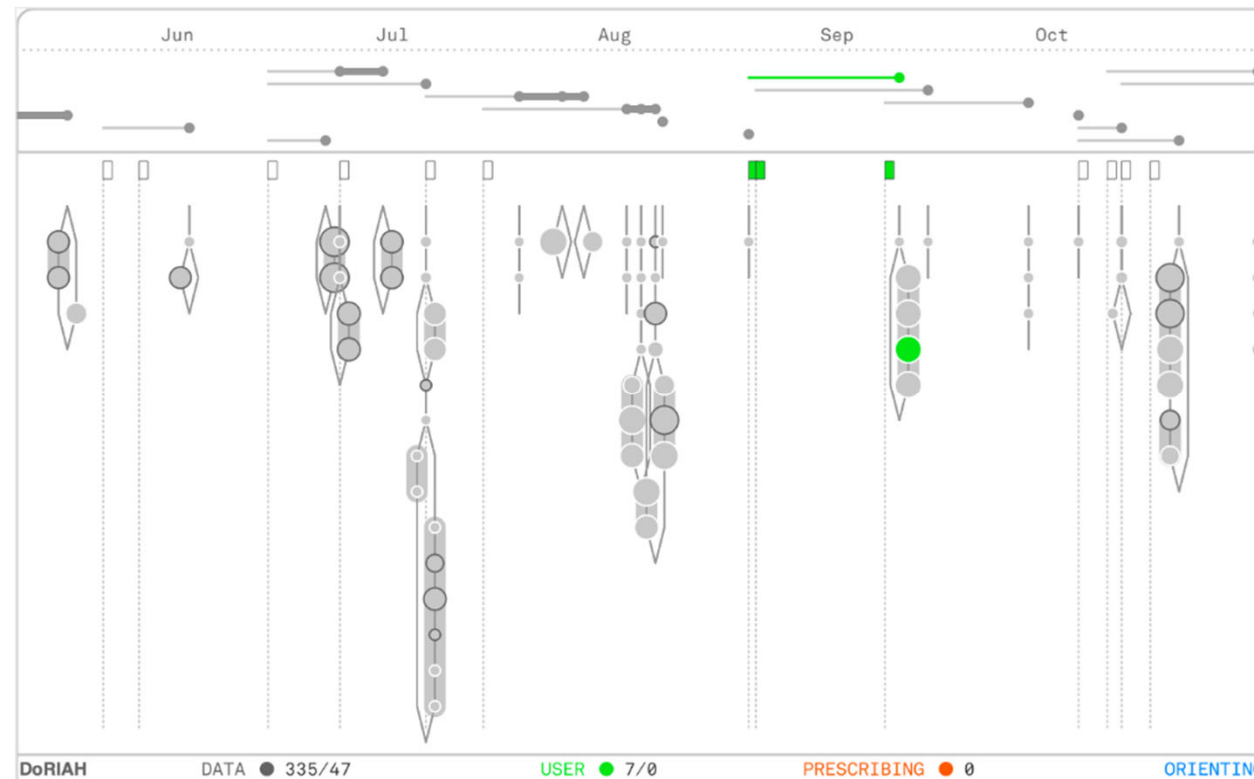
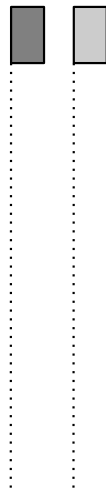

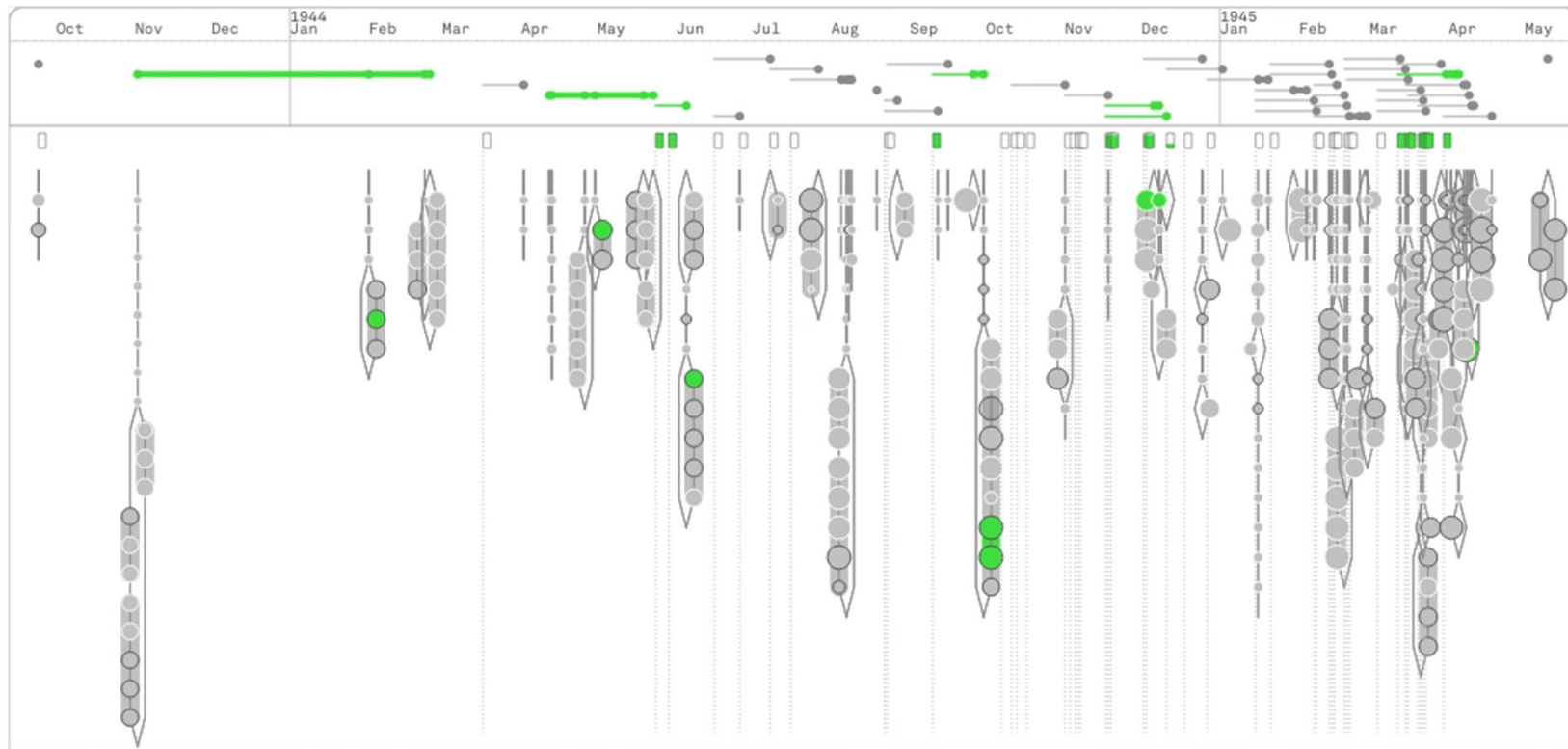

DoRIAH DATA ● 332/47 USER ● 8/0 PRESCRIBING ● 0 ORIENTING ●

Map **Geoland Basemap Orthofoto** Aerials [Navigation icons]

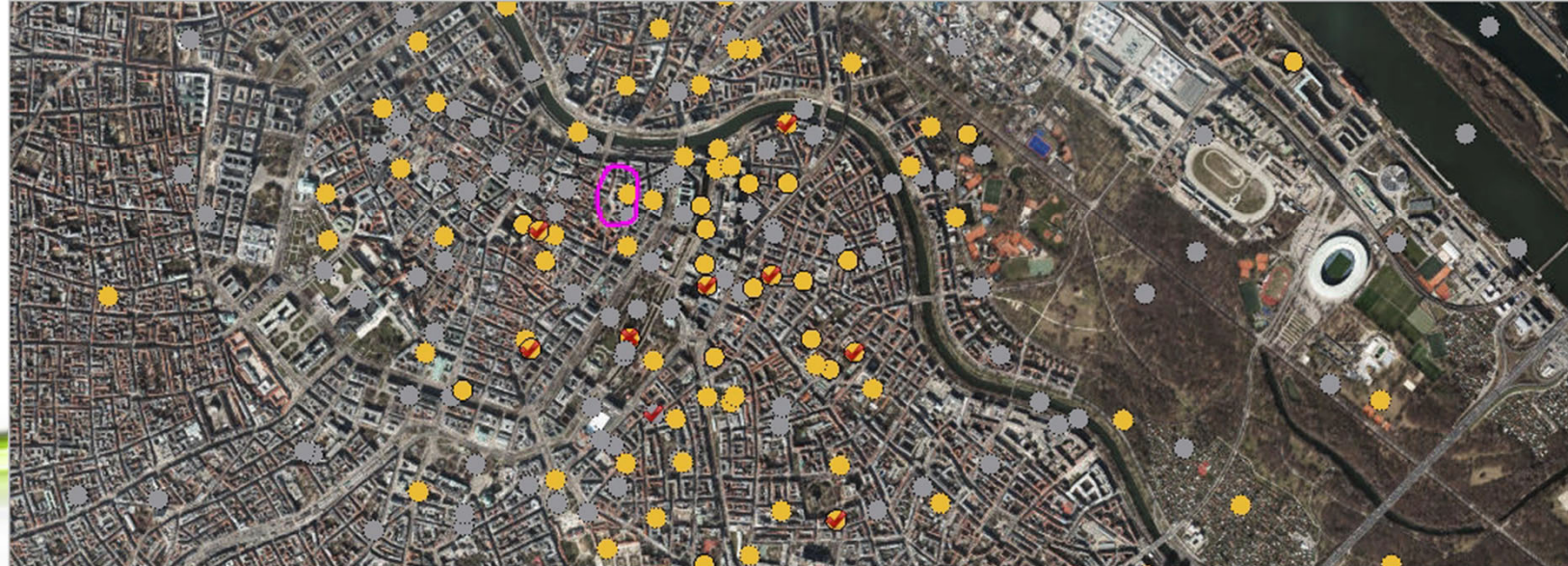

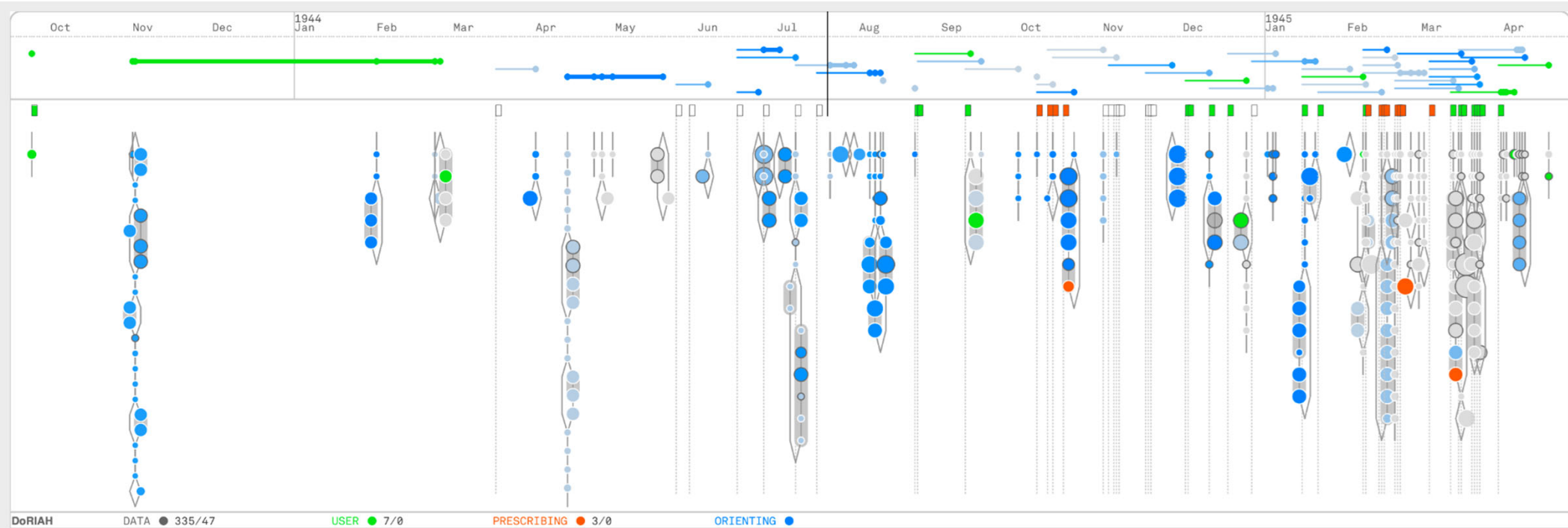

Map **Geoland Basemap Orthofoto** [Navigation icons] Aerials [Aerials icons] [Map controls icons]

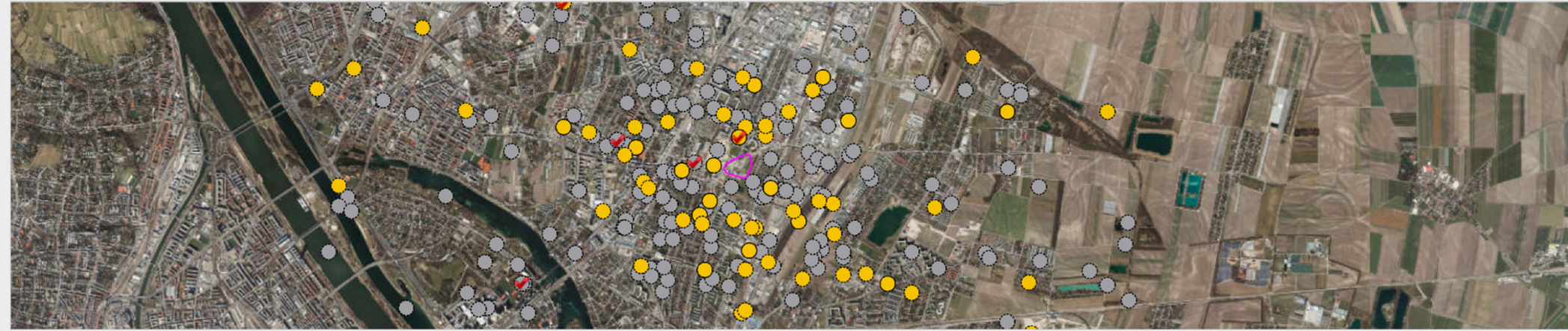

Response time: 00:00.01 00:35 ago Map resolution: 0.149m Showing 335 of 335 aerials [Help] [OK]

Co-Adaptive Guidance

Learning & Training

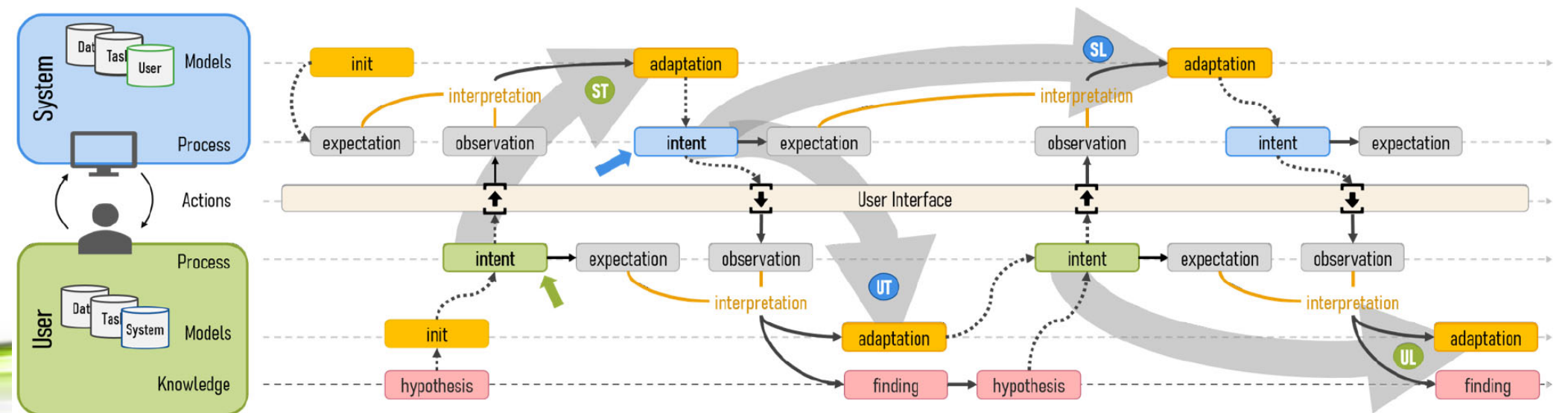

Content

Motivation & Contextualization

Data, Users, & Tasks → Information & Knowledge

Visual Analytics (VA)

Mixed-Initiative Process & Challenges

Guidance-Enriched VA

Models and Concepts

Exempels & Insights

Knowledge-Assisted VA

Models and Concepts

Exempels & Insights

Challenges & Opportunities

Conclusion



KNOWLEDGE-ASSISTED VA



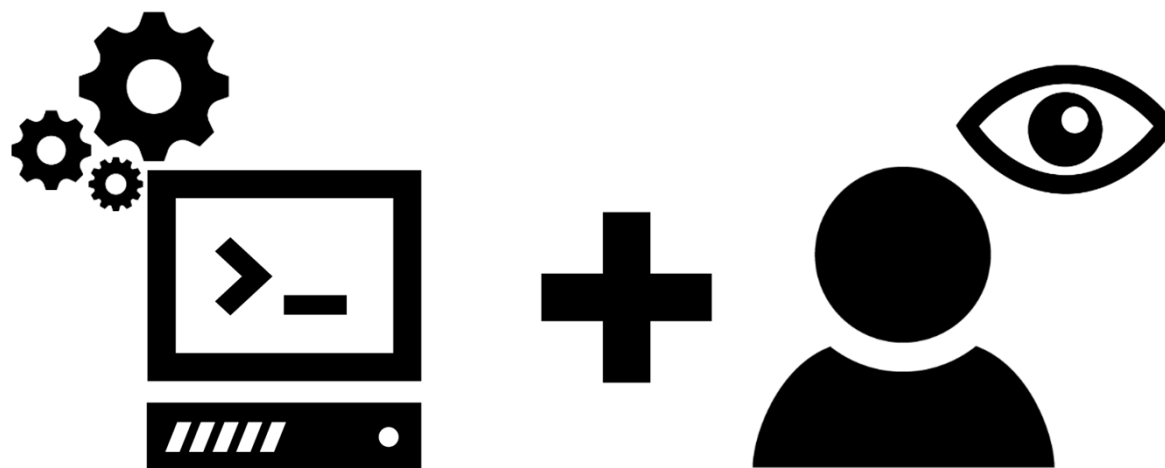

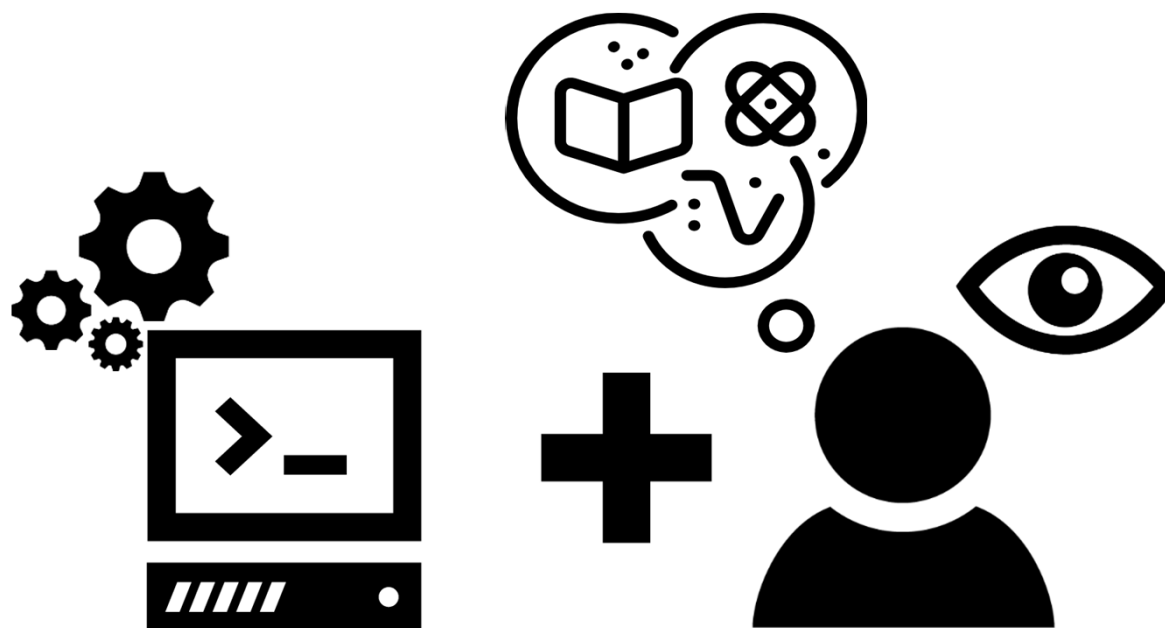

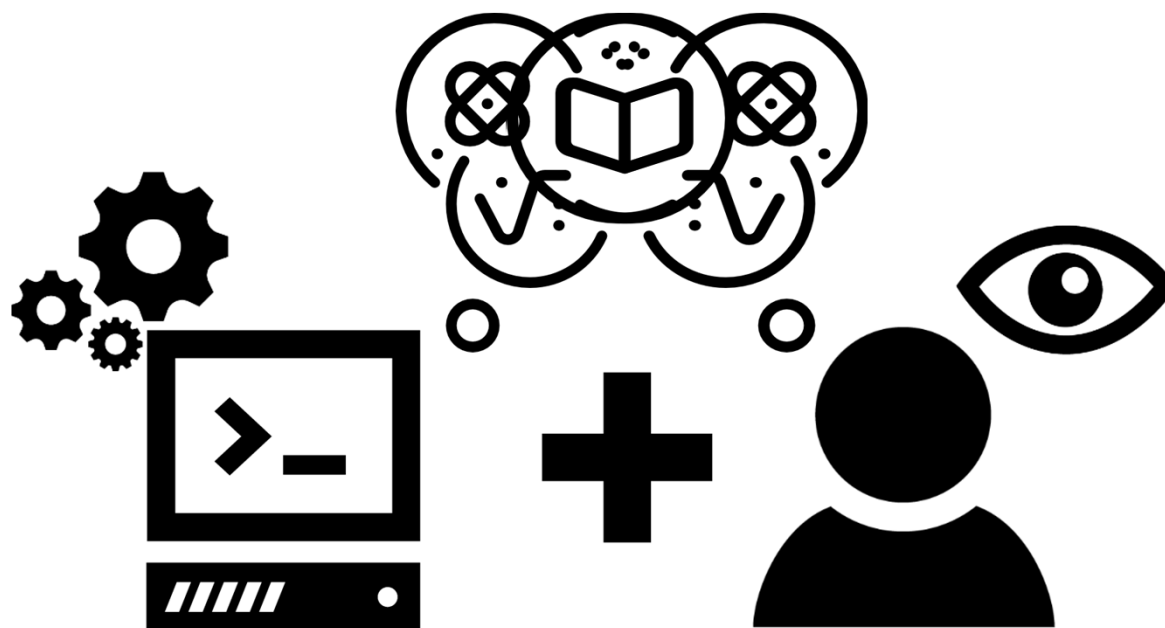

Explicit Knowledge

... that can be processed by a computer, transmitted electronically, or stored in a database

Tacit Knowledge

... is personal, specialized, and can only be extracted by a human

Operational Knowledge

how to interact with the visualization system

Domain Knowledge

how to interpret the content



Knowledge-Assisted VA – Approach

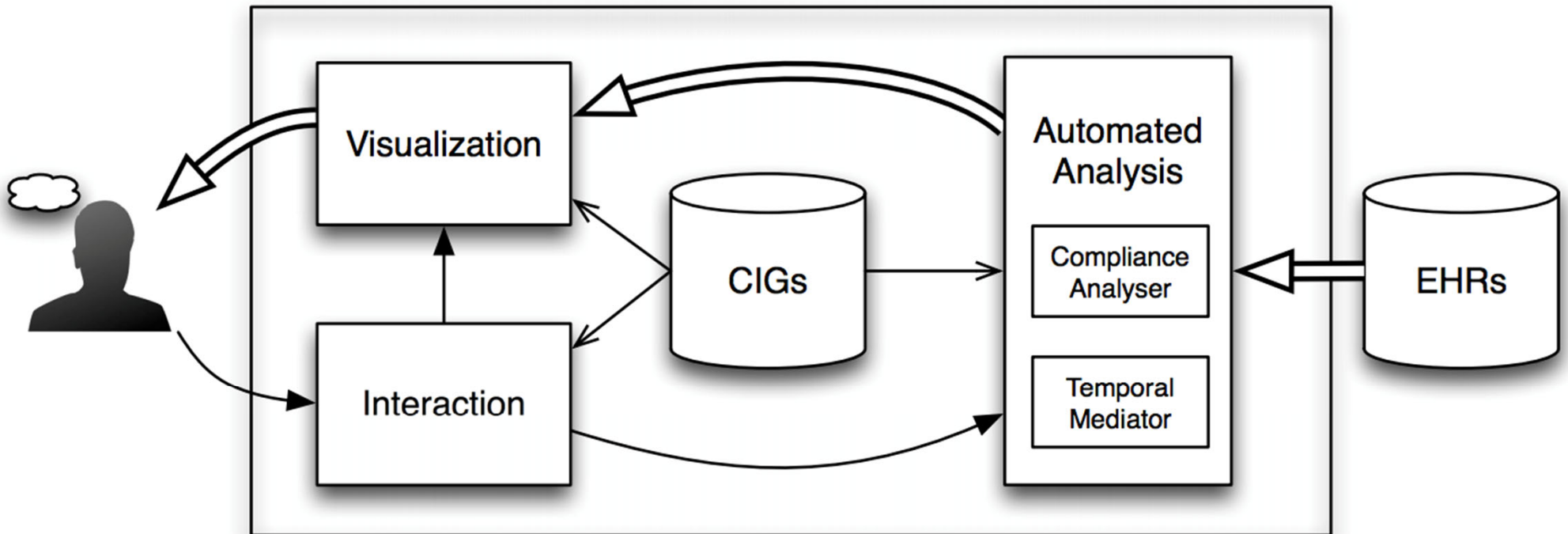

Knowledge-Assisted VA – Processes

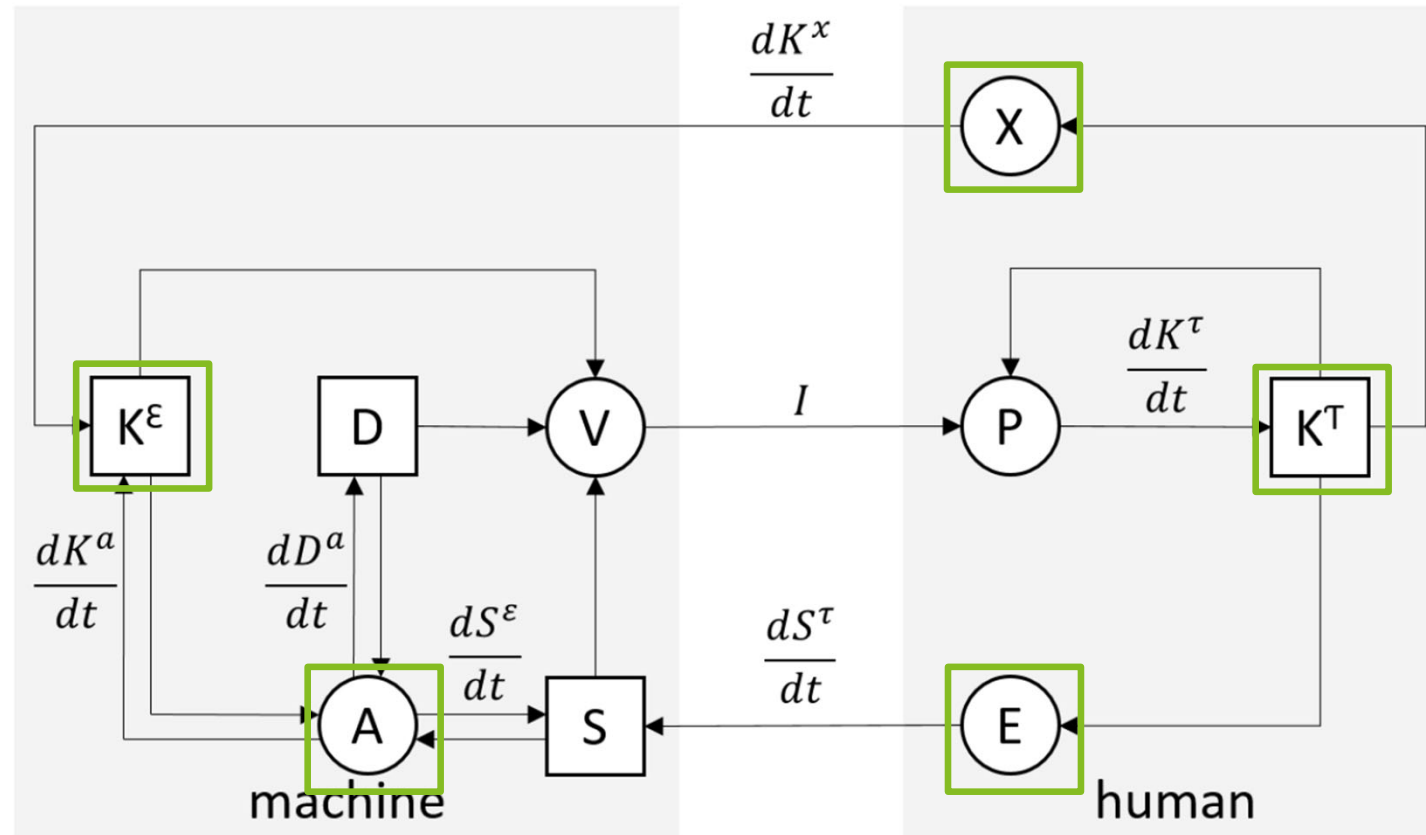

- $\square D$ data
- $\square S$ specification
- $\square K^\tau$ tacit knowledge
- $\square K^\epsilon$ explicit knowledge
- I image
- $\circ V$ visualization
- $\circ P$ perception
- $\circ A$ analysis
- $\circ X$ externalization
- $\circ E$ exploration

Characterizing Analysis

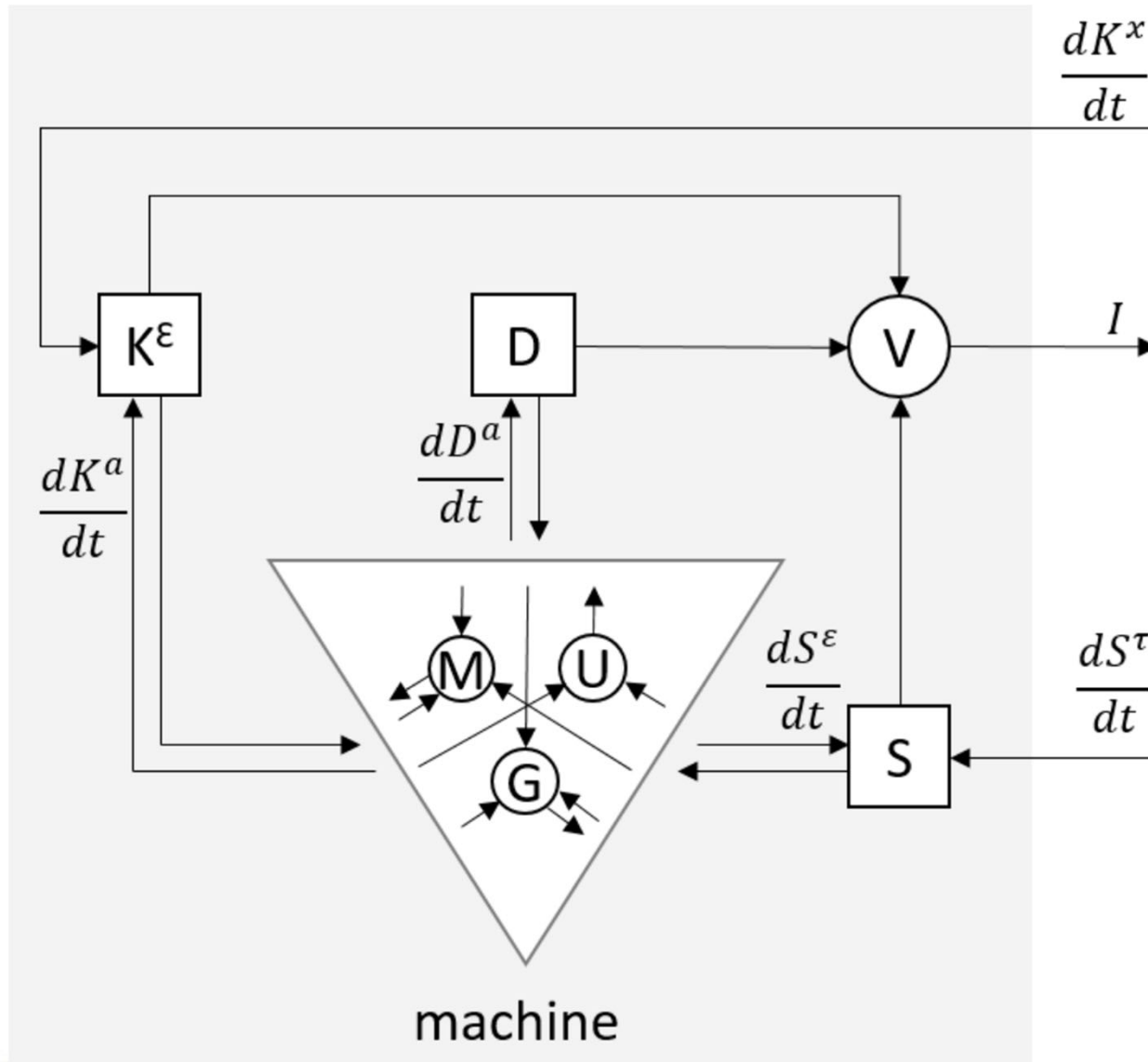

- (M) mining
- (U) simulation
- (G) guidance

CareCruiser Project

CVAST
www.cvast.tuwien.ac.at

[Gschwandtner, et al., 2010-2011]

Interactive Exploration of Effects of Therapeutic Actions on a Patient's Condition



European Commission
Information Society and Media



Laura Bassi Centre of Expertise
Centre for Visual Analytics
Science & Technology

Wolfgang Aigner, Theresia Gschwandtner,
Katharina Kaiser, Silvia Miksch, Andreas Seyfang



CareCruiser

[Gschwandtner, et al., 2010, 2011]

Users

Medical Experts and
Physicians

Data

Patient Data and
Treatment Plans

Data: multivariate,
abstract

Time: linear, instant

Task

Exploring the Effects of
Clinical Actions on a
Patient's Condition

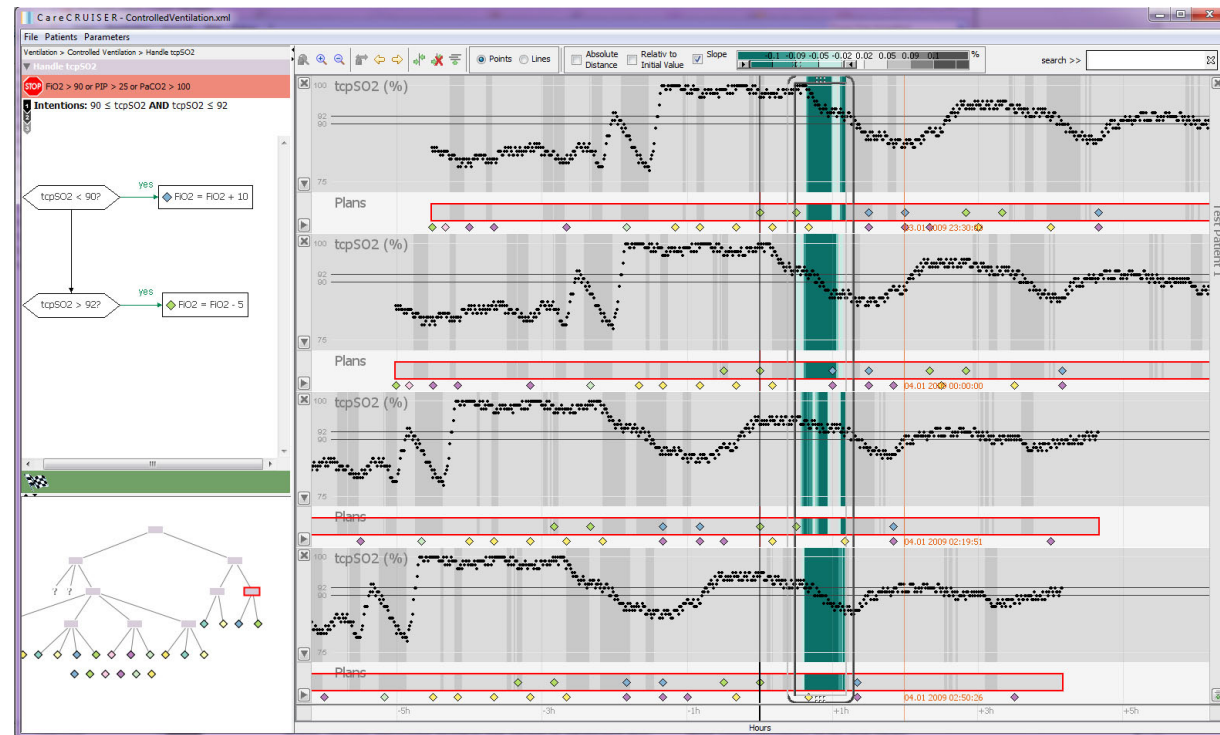

Communicating Different Aspects with Multiple Views

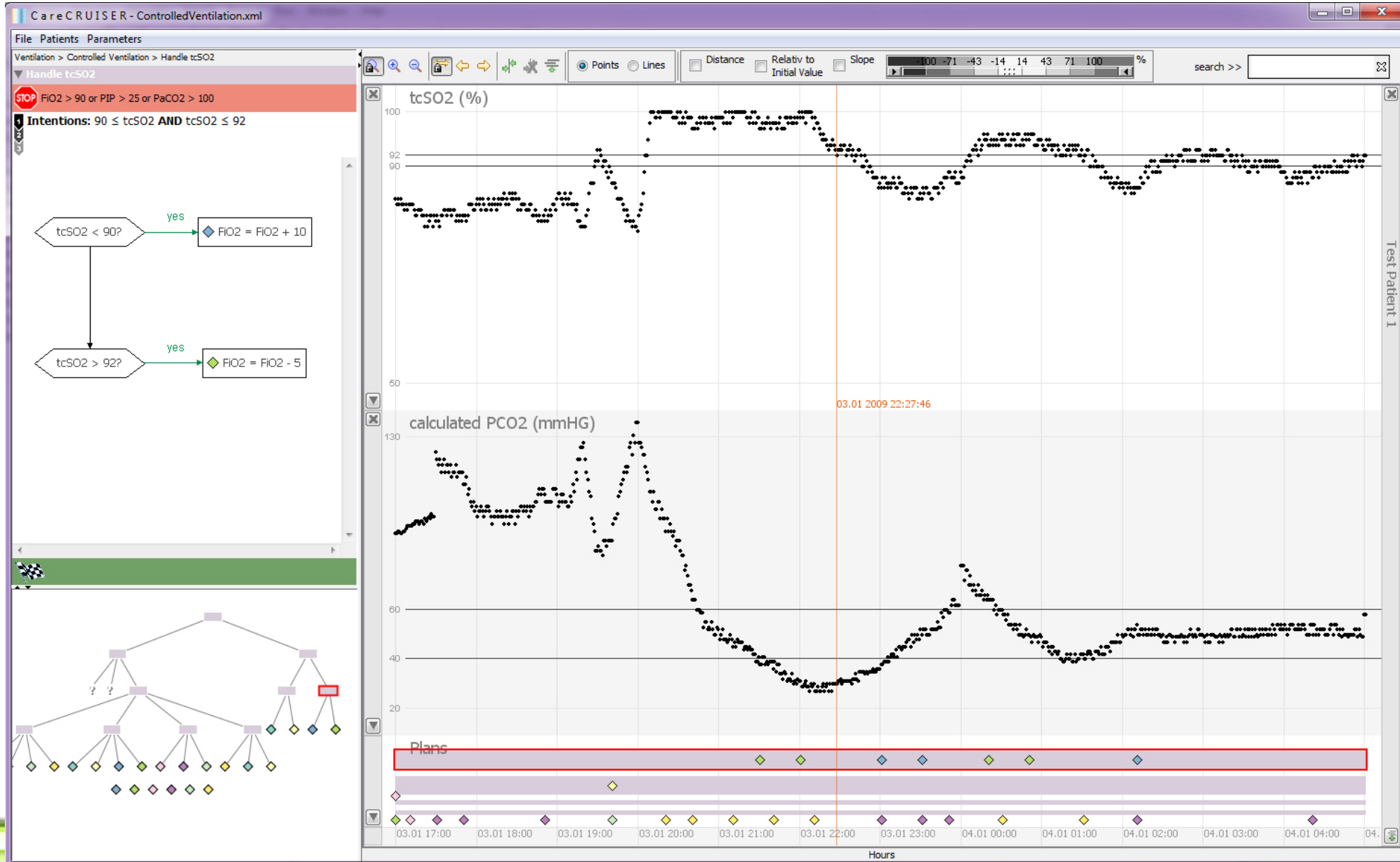

Aligning Clinical Actions

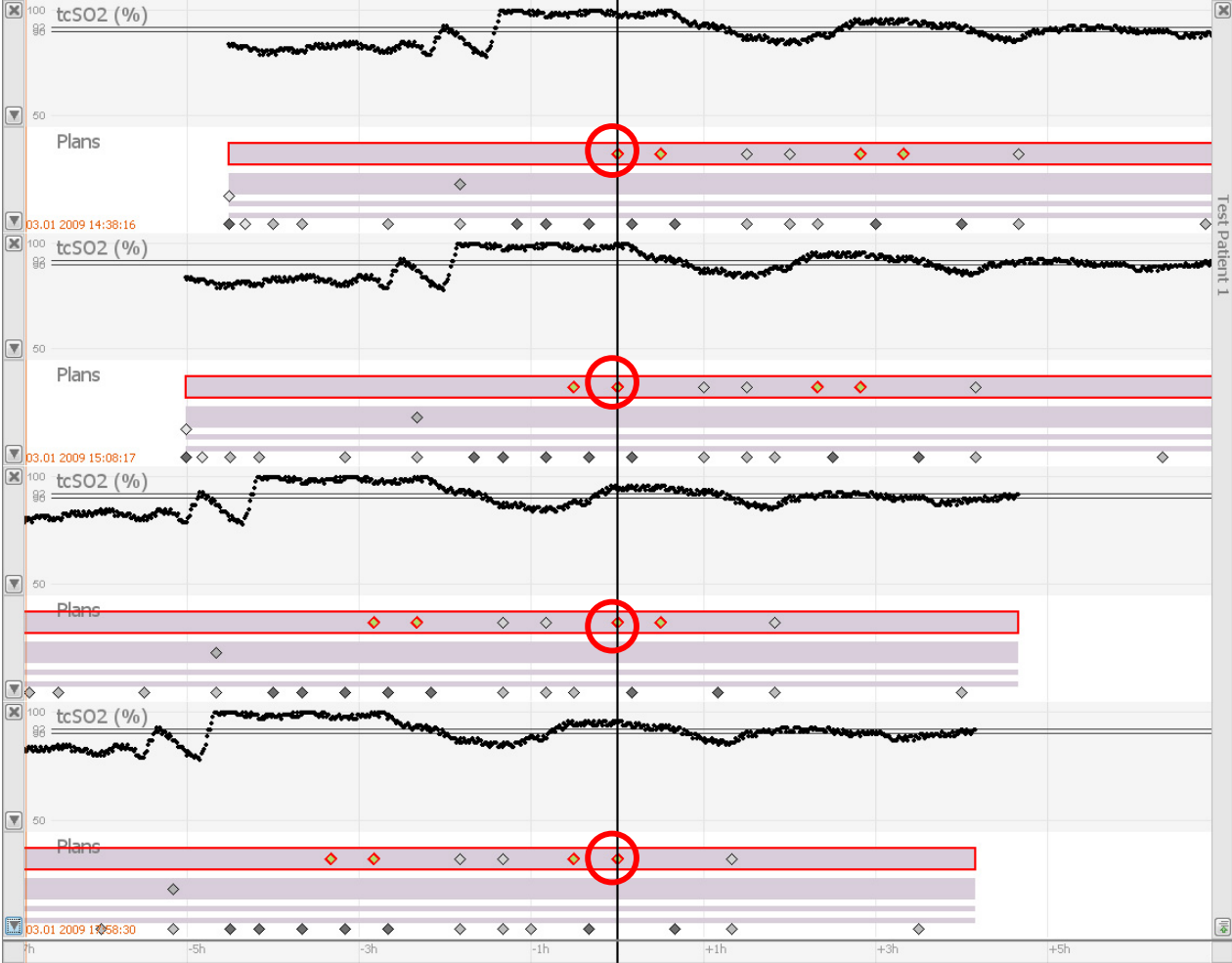

Color-Coding Effects of Actions/Treatments

Distance from intended value range

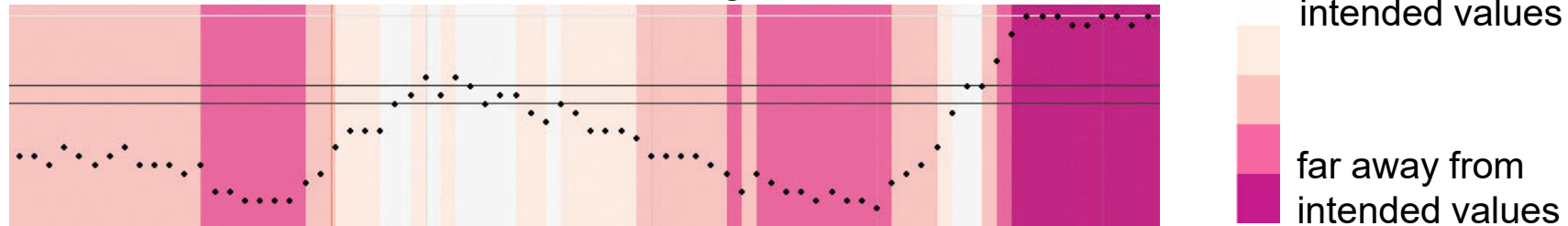

Progress from initial value (at start of the treatment)

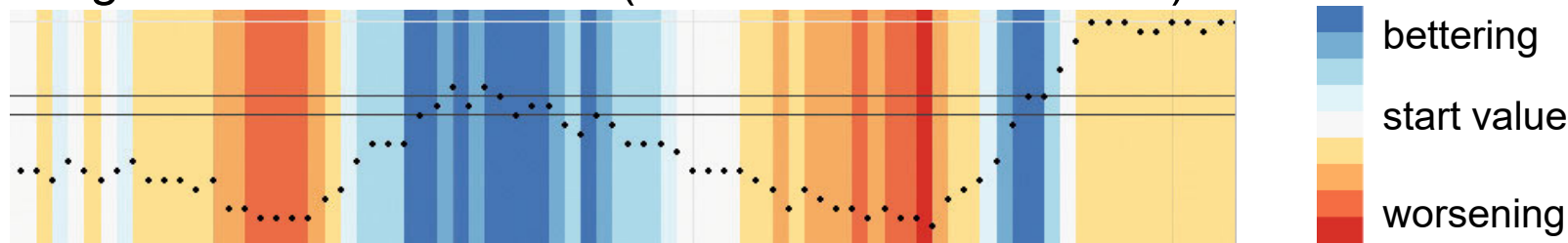

Slope

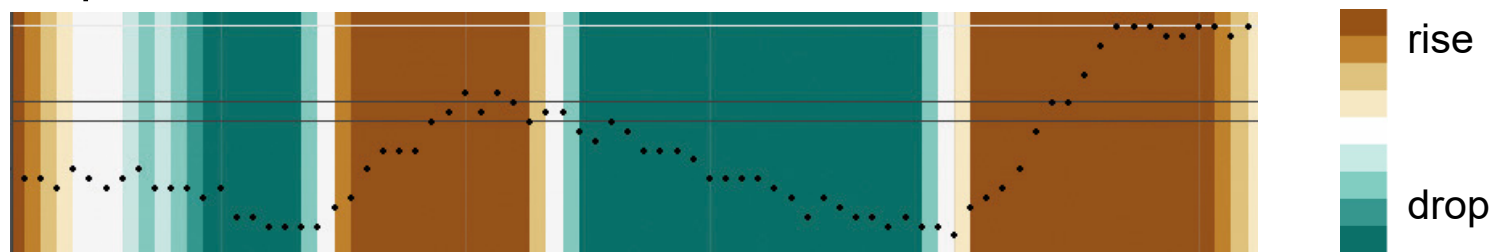

CareCruiser Video

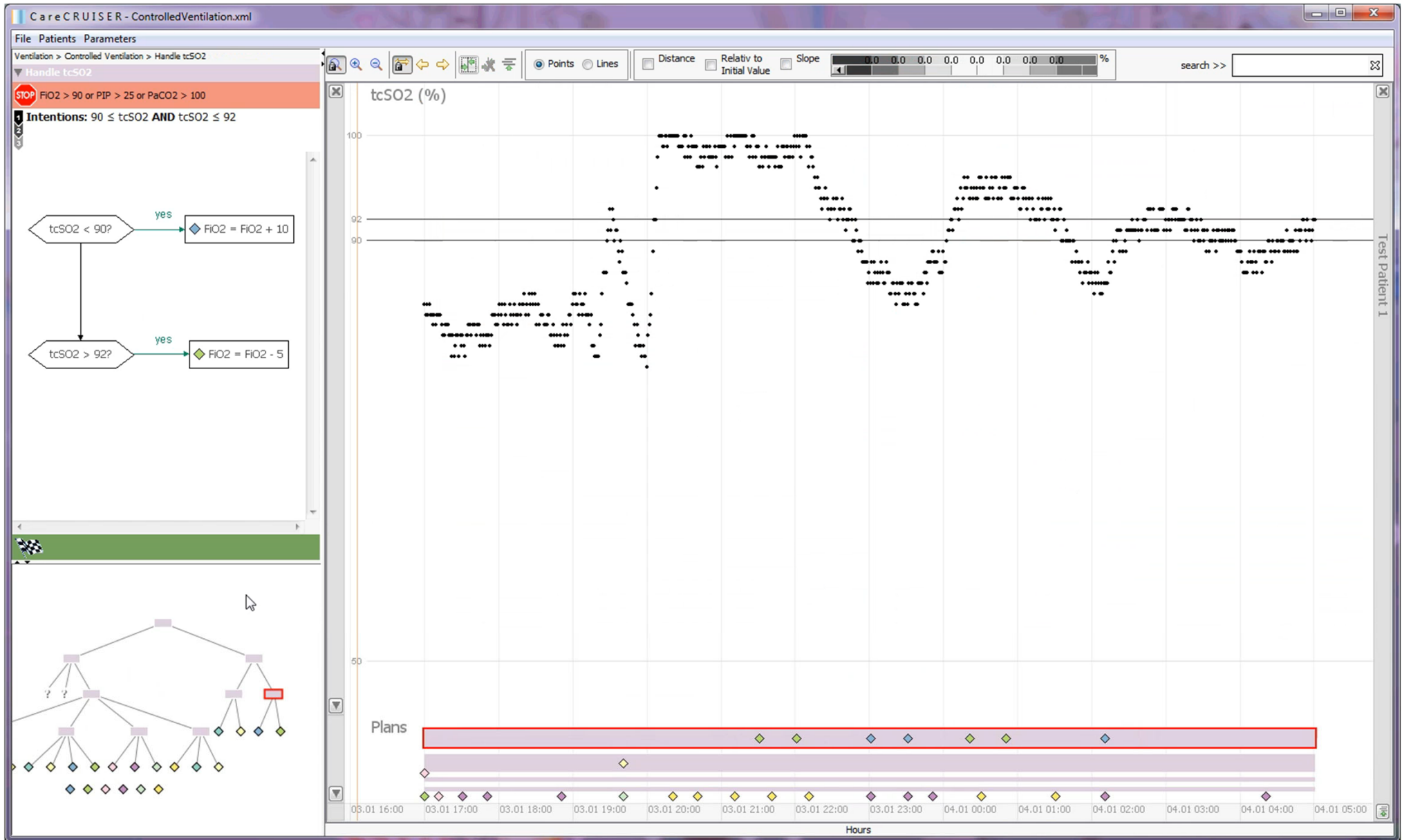

CareCruiser

[Gschwandtner, et al. : CareCruiser]

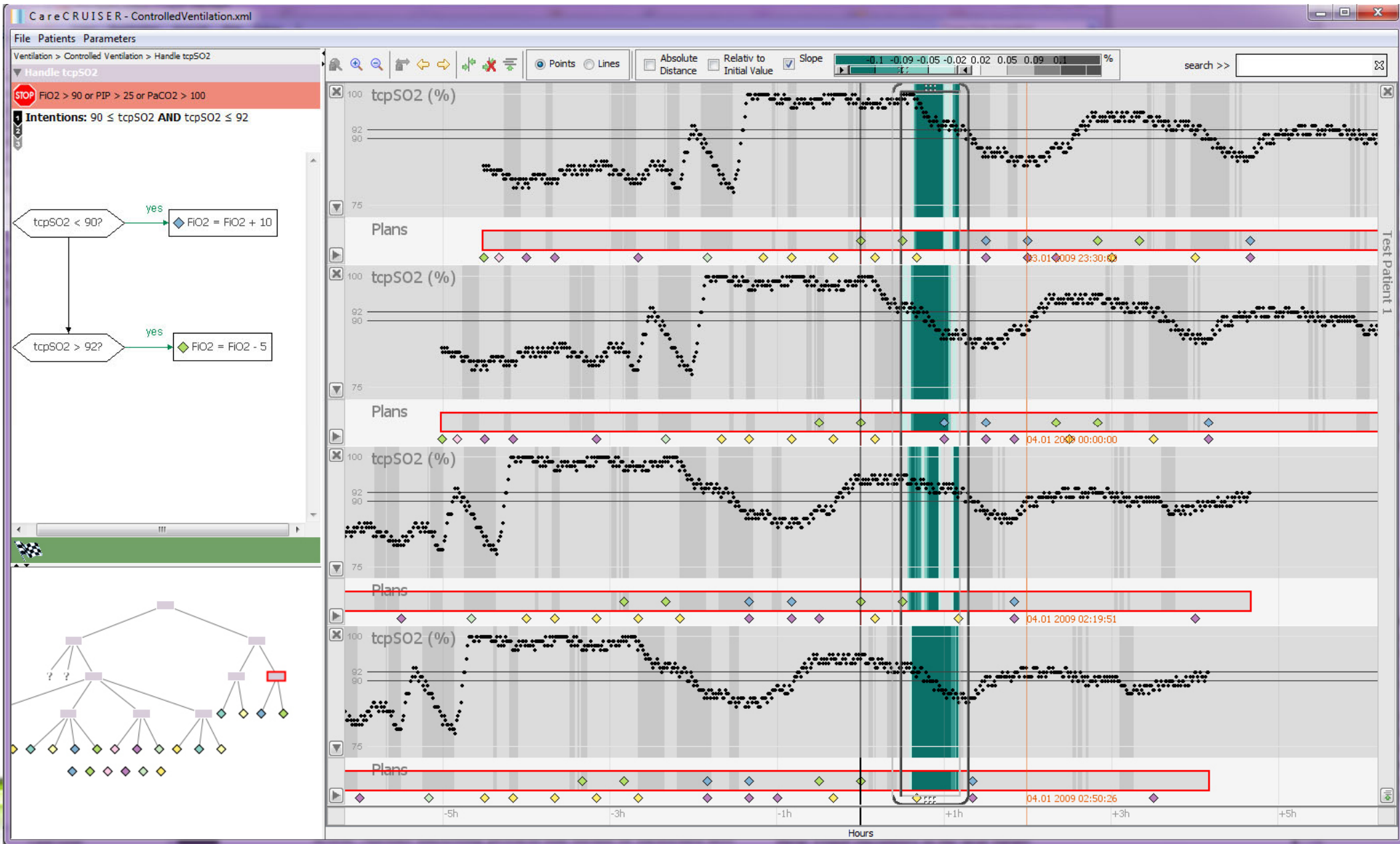

IMMV: Interactive Music Mapping Vienna: Exploring a City, 1945 up to the Present Day

Exiled but not Forgotten: A Visual Analytics Approach
to Investigate Posthumous Commemoration

FWF PEEK
Der Wissenschaftsfonds.

Paolo Federico, **Velitchko Filipov**,
Victor Schetinger, Silvia Miksch

TU
WIEN Informatics

Susana Zapke, Stefan Schmidl, Rosemarie Burgstaller,
Paul Lohberger, Georg, Kö, Kathrin Raminger, et al.

**MUSIK
UND
KUNST**
MUK PRIVATUNIVERSITÄT
DER STADT WIEN

IMMV

... focus is the valorisation and the mediation of the capabilities of music as an **urban identification tool**.

The interaction between music and urban texture (identity, political symbolism, mental determination, imagination) should be made accessible to academic and to a wide audience through interactive **Visual Analytic Technologies**.



Interactive Music Mapping Vienna

Exploring a City. 1945 up to the Present Day
*Interdisziplinäres Forschungsprojekt
am Institut für Wissenschaft und Forschung*

Projektleitung: Univ.-Prof.ⁱⁿ Dr.ⁱⁿ Susana Zapke
Wissenschaftliches Team: Univ.-Prof.ⁱⁿ Dr.ⁱⁿ Silvia Miksch (ISIS, TU Wien),
Univ.-Prof. Dr. Stefan Schmidl, Dr.ⁱⁿ Rosemarie Burgstaller

Laufzeit: Beginn 2017, Dauer 3 Jahre

Nationale Forschungspartnerin:
Institute of Software Technology & Interactive Systems (ISIS),
Technische Universität Wien

Gefördert von:
FWF – Fonds zur Förderung der wissenschaftlichen Forschung
AR 384-G24 Programm zur Entwicklung und Erschließung
der Künste (PEEK)



Wissenschaftliche KooperationspartnerInnen:



www.muk.ac.at

Exiled but not Forgotten ...

Users

Domain Experts (Humanist)

Data

Event-based Networks

Multivariate, abstract

Time: linear, instant

Space

Task [Brehmer and Munzner, 2013]

Present

Compare

Explore

Verify

INTERACTIVE MUSIC MAPPING VIENNA

Musikstadt Wien Reloaded
Republik- und Staatsvertragsfeste
Ikonisierung und Ehrung
Stadtffeste
ARBEITER*INNENFESTE
Stadtbranding
Erinnerungskultur
ILLUSIONSRAUM PRATER
Populärmusik
Protestbewegungen
ALLEEVENTS

OBERIMMV ANLEITUNG
DATENSCHUTZ IMPRESSUM

Zum Essay THEMA ERKUNDEN

Musikstadt Wien Reloaded

Der Wiederaufbau vom Ende des Zweiten Weltkrieges bis zur Unterzeichnung des Staatsvertrags 1955 war - auch musikalisch - geprägt von der vierfachen militärischen Besetzung und großer Armut, aber auch von einer enthusiastischen Aufbruchsstimmung und von der Wiederbelebung des kulturellen Lebens. „Wiederaufbau“ bedeutet: Wiederherstellung demokratischer Strukturen, Wiederaufbau der zerstörten Stadt, aber auch Wiederanknüpfung an kulturelle „Traditionen“ verbunden mit der Neuprägung einer österreichischen Identität.

Wiener Musikverein
Festkonzert zum ersten
Jahrestag der Befreiung Wien
(1946)

1/5

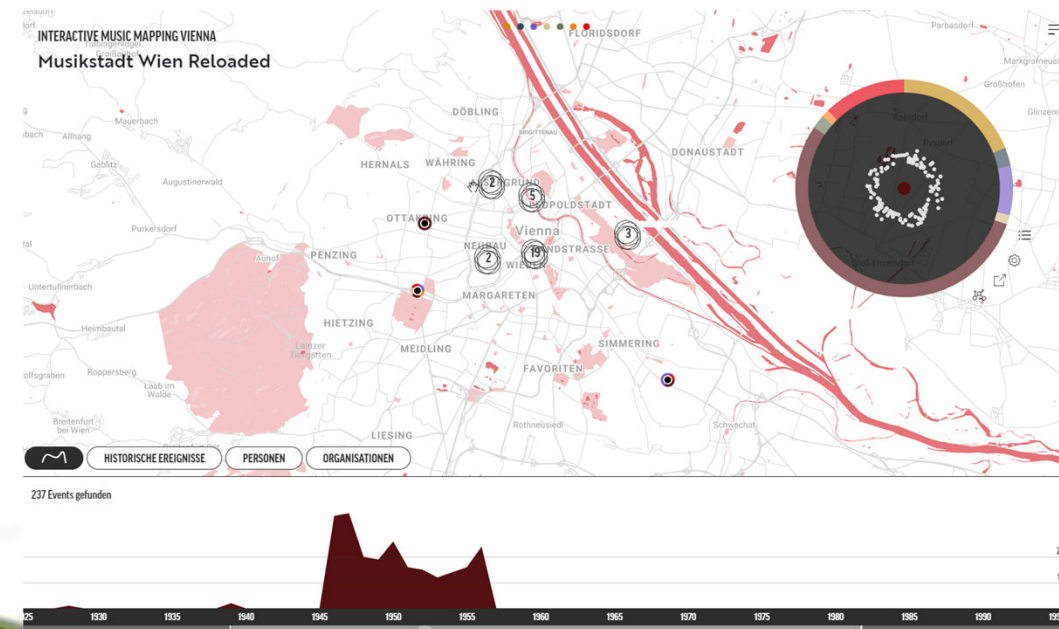

Circular: Visualization Prototype

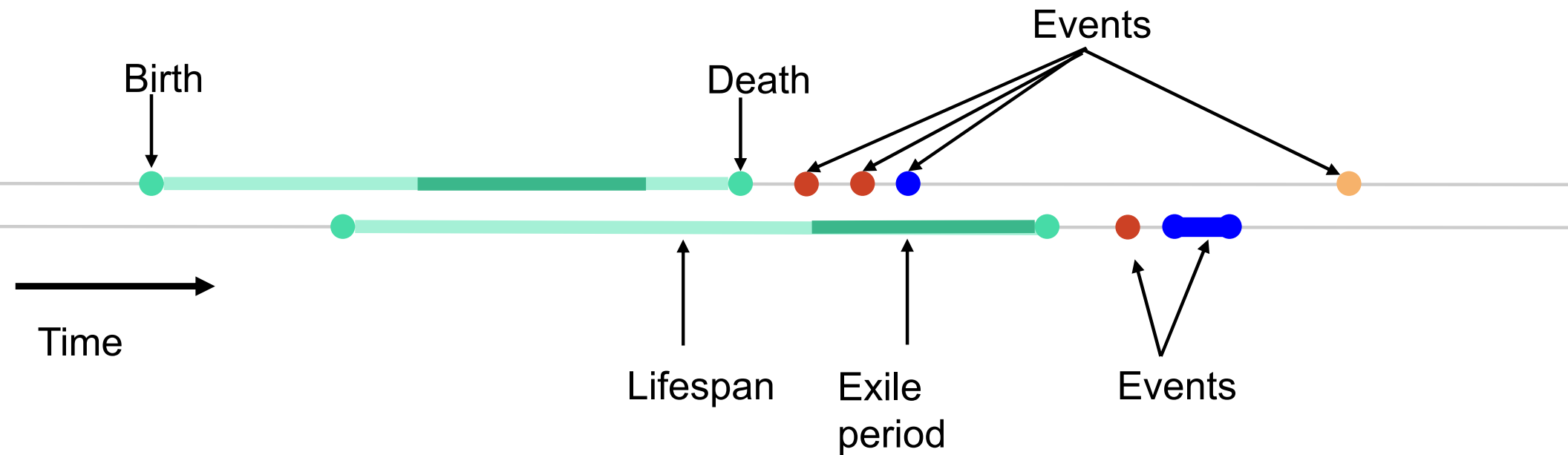

Circular: Visualization Prototype

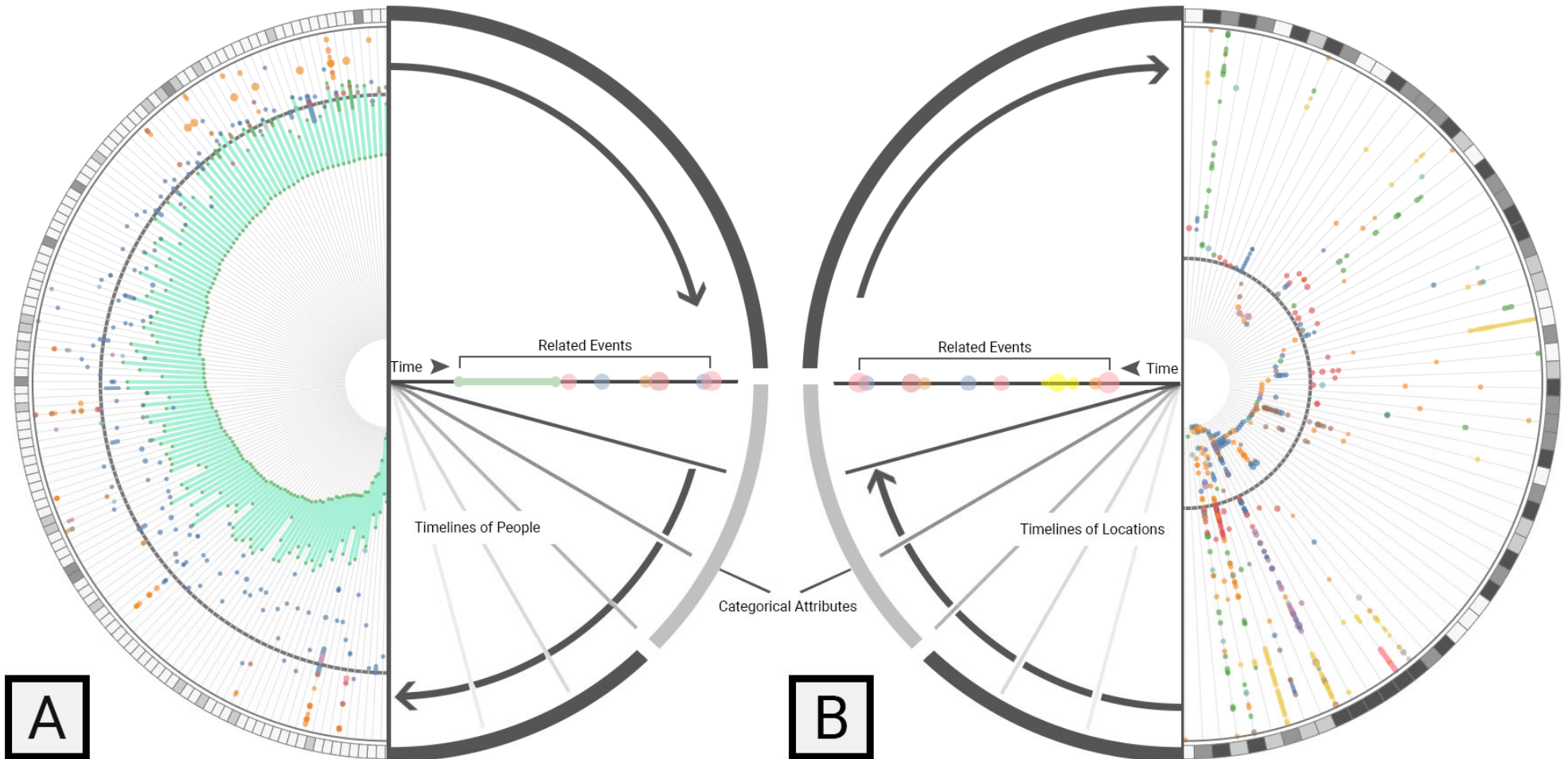

Circular: Visualization Prototype

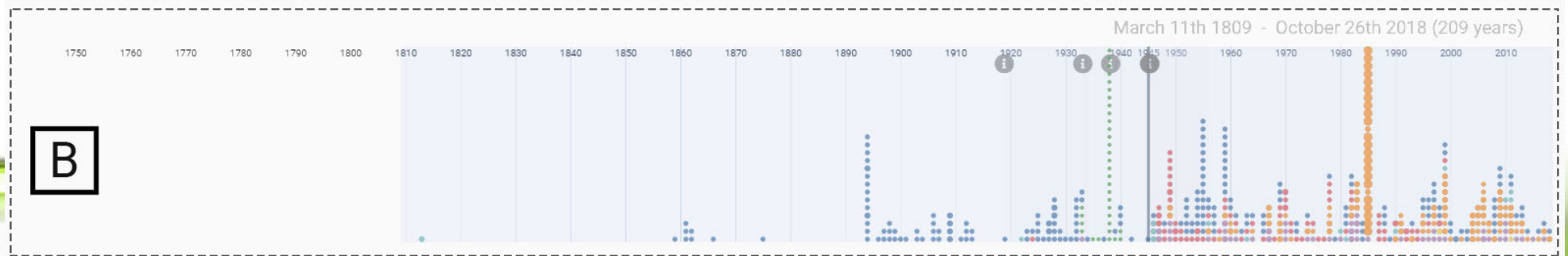
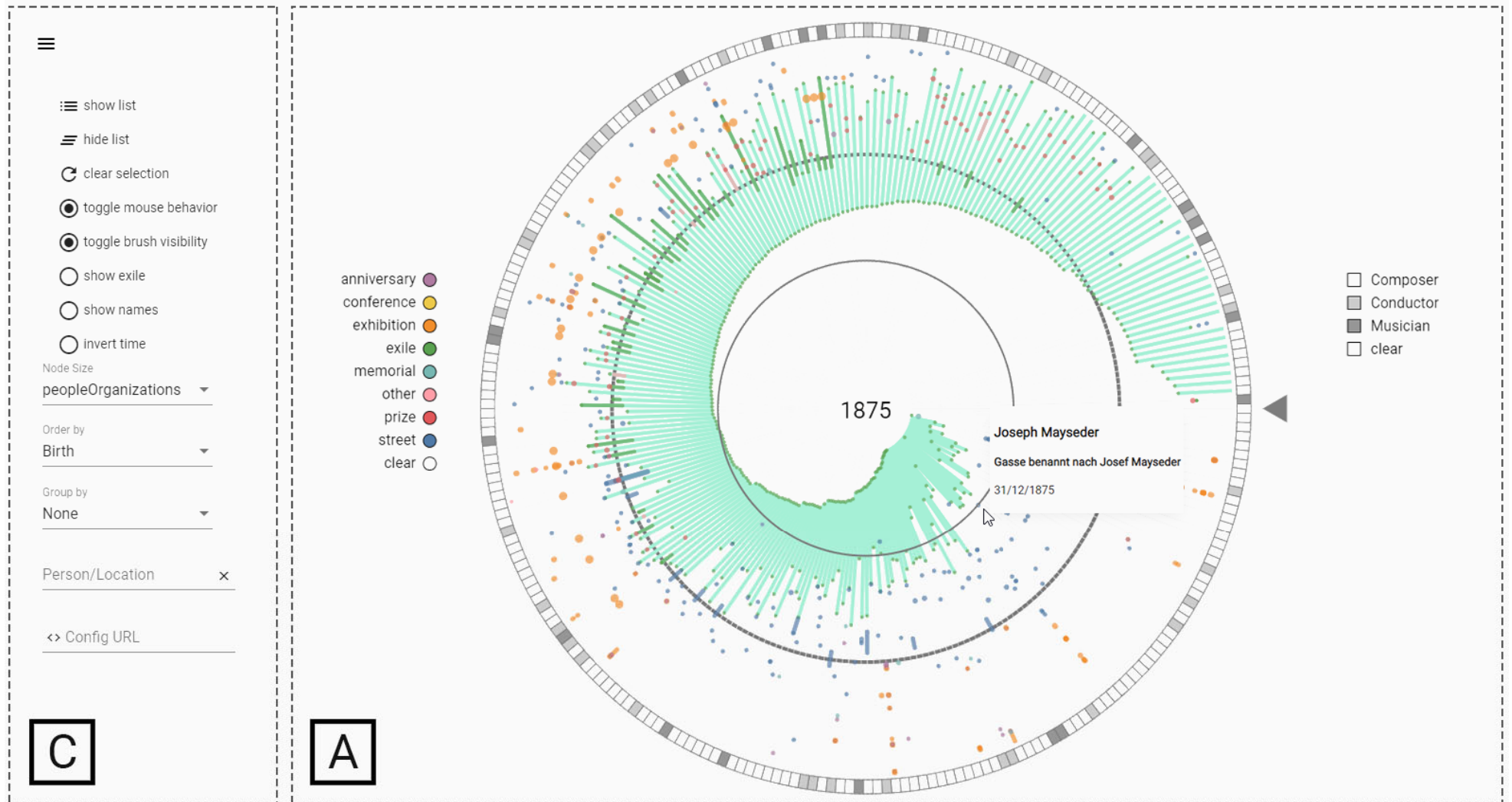

Circular: Visualization Prototype

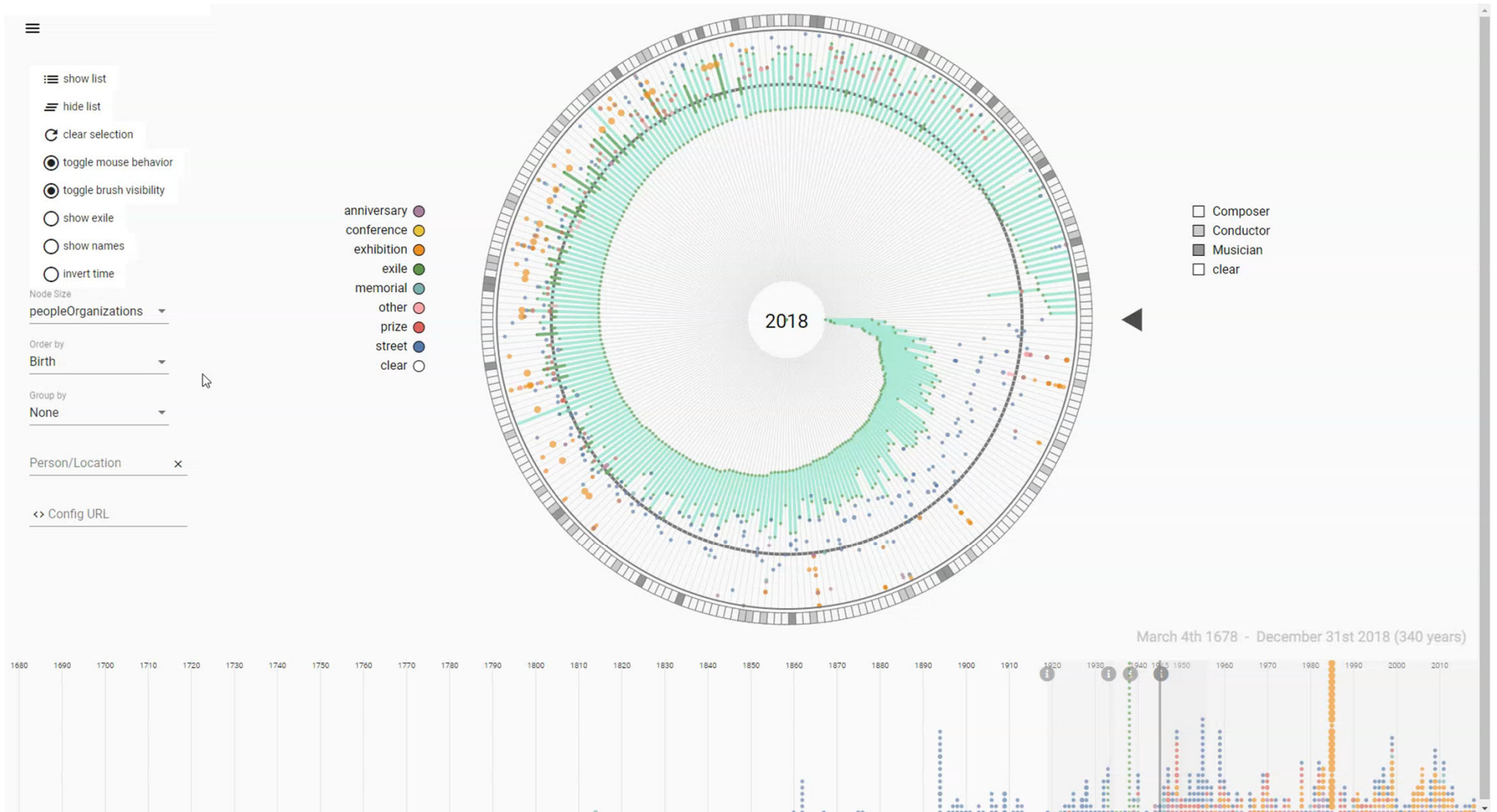

Circular: Visualization Prototype

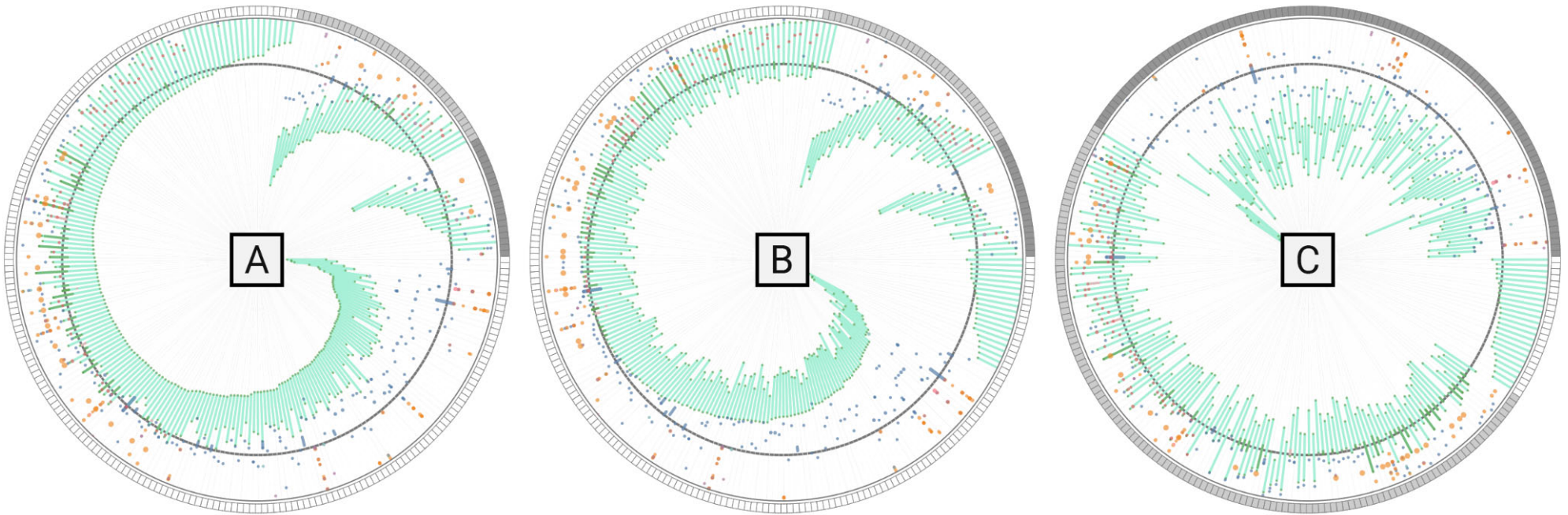

ArtVis: Dynamic Network Perspectives on Digital Art History

Mapping the Avantgarde: Visualizing Modern Artists' Exhibition Activity

FWF

Der Wissenschaftsfonds.

Velitchko Filipov,

 Informatics

Michaela Tuscher, Victor Schetinger, Silvia Miksch

Teresa Kamencek, Raphael Rosenberg



universität
wien

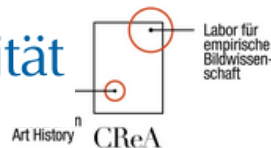

Mapping the Avantgarde ...

Users

Domain Experts (Art Humanist)

Data

DOME

Event-based Networks

Multivariate, abstract

Time: linear, instant

Space

Task

Detecting geospatial and temporal (exhibition) patterns

Grouping/ordering the exhibitions by different attributes

Comparing artists' exhibition patterns

Database of Modern Exhibitions (DoME)

<https://exhibitions.univie.ac.at/>

CVAST
www.cvast.tuwien.ac.at

[Rosenberg, et al.]

Project by University of Vienna

European Paintings and Drawings between 1905 and 1915

Contains

- > 13,000 artists
- > 1,300 exhibitions
- > 207,000 paintings
- > 300 venues

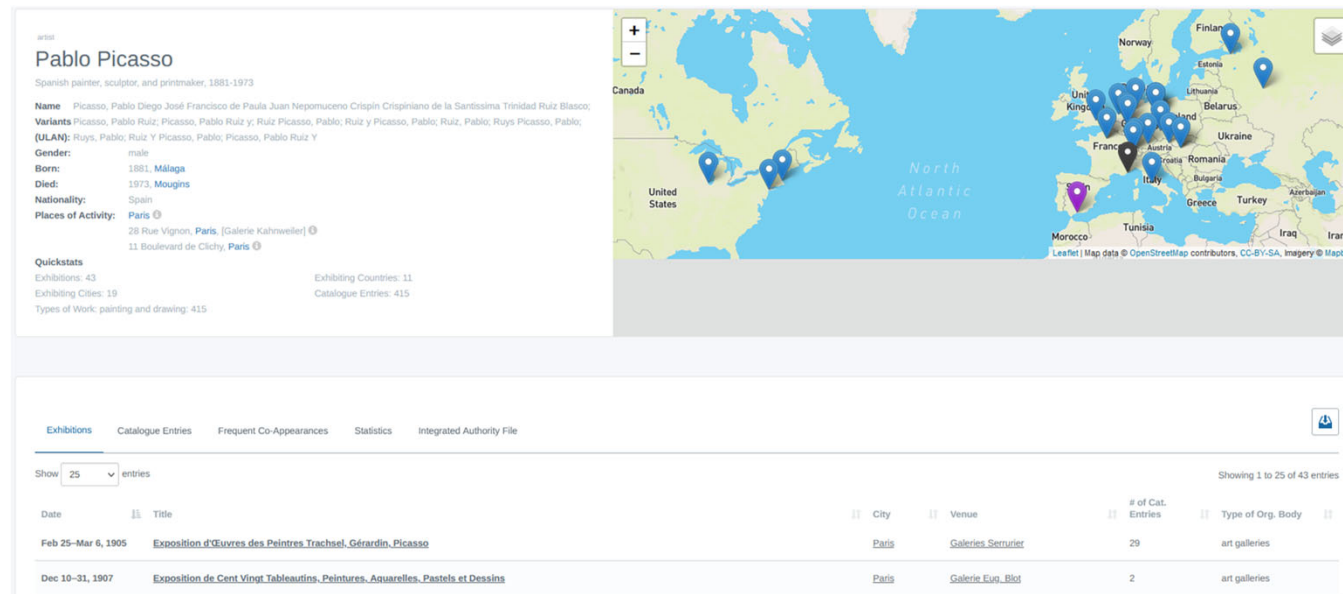

Pablo Picasso
Spanish painter, sculptor, and printmaker, 1881-1973

Name: Picasso, Pablo Diego José Francisco de Paula Juan Nepomuceno Crispín Crispiniano de la Santísima Trinidad Ruiz Blasco
Variants: Picasso, Pablo Ruiz; Picasso, Pablo Ruiz y; Ruiz Picasso, Pablo; Ruiz y Picasso, Pablo; Ruiz, Pablo; Ruys Picasso, Pablo;
(ULAN): Ruys, Pablo; Ruiz Y Picasso, Pablo; Picasso, Pablo Ruiz Y
Gender: male
Born: 1881, Málaga
Died: 1973, Mougins
Nationality: Spain
Places of Activity: Paris, [Galerie Kahnweiler] 28 Rue Vignon, Paris, [Galerie Kahnweiler] 11 Boulevard de Clichy, Paris

Quickstats
Exhibitors: 43 Exhibiting Countries: 11
Exhibiting Cities: 19 Catalogue Entries: 415
Types of Work: painting and drawing: 415

Exhibitions Catalogue Entries Frequent Co-Appearances Statistics Integrated Authority File

Show 25 entries Showing 1 to 25 of 43 entries

Date	Title	City	Venue	# of Cat. Entries	Type of Org. Body
Feb 25–Mar 6, 1905	Exposition d'Œuvres des Peintres Trachsel, Gérardin, Picasso	Paris	Galerie Serurier	29	art galleries
Dec 10–31, 1907	Exposition de Cent Vingt Tableaux, Peintures, Aquarelles, Pastels et Dessins	Paris	Galerie Eug. Btg	2	art galleries



Geospatial and Temporal Patterns

Pierre-Auguste Renoir

Pierre-Auguste Renoir (FR)
1841 (Limoges) - 1919 (Cagnes-sur-Mer)
90 exhibitions | 561 artworks

Type	Date	City	Country	Title	Catalogue Entries	Base %Entries	Artists	Host	Hosttype
group	1905	Venice	IT	VI. Esposizione d'Arte della Città di Venezia	1257	0.27%	396	Città di Venezia	others
group	1905	Paris	FR	Salon d'Automne. 3e Exposition	1790	0.64%	452	Société du Salon d'Automne	arts associati...

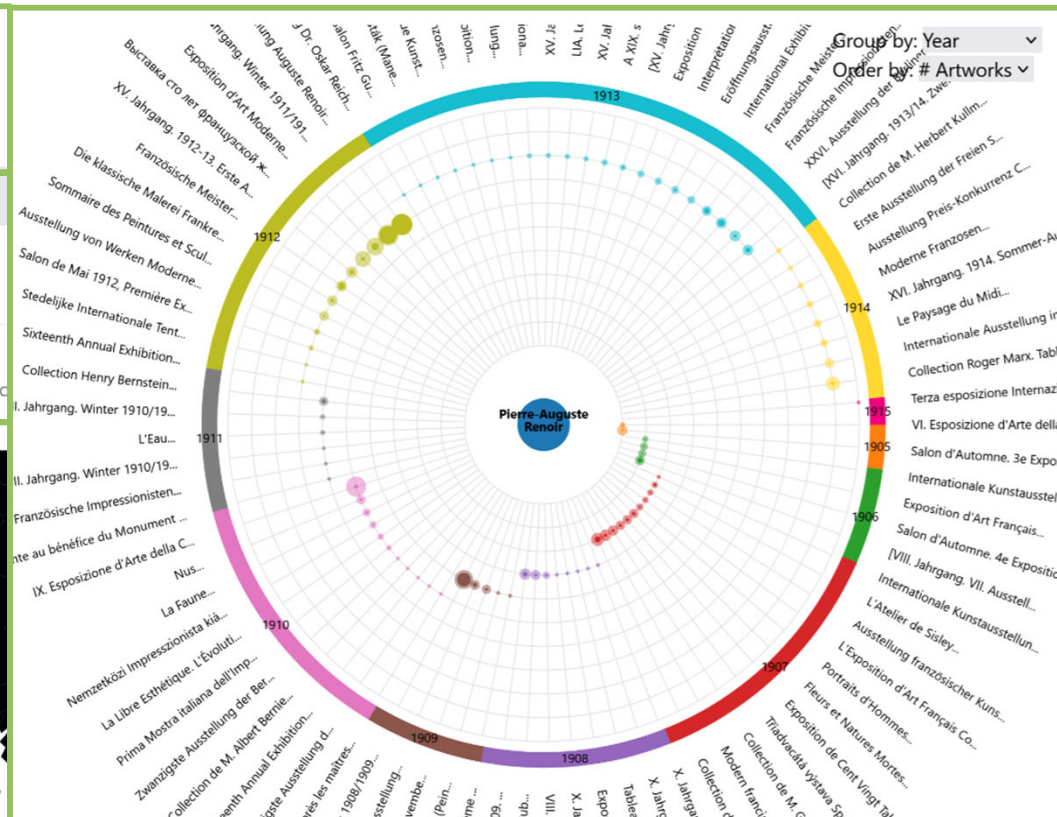
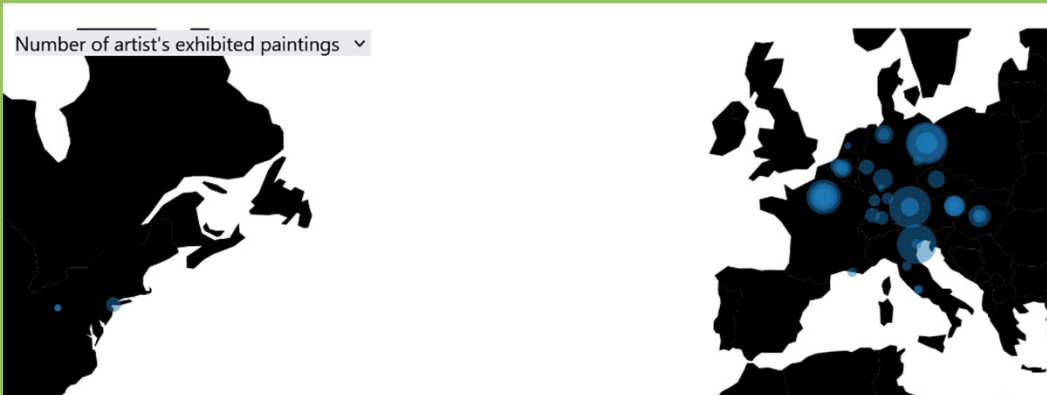

Multiple Perspectives (T3)

Pablo Picasso

Exhibition Types

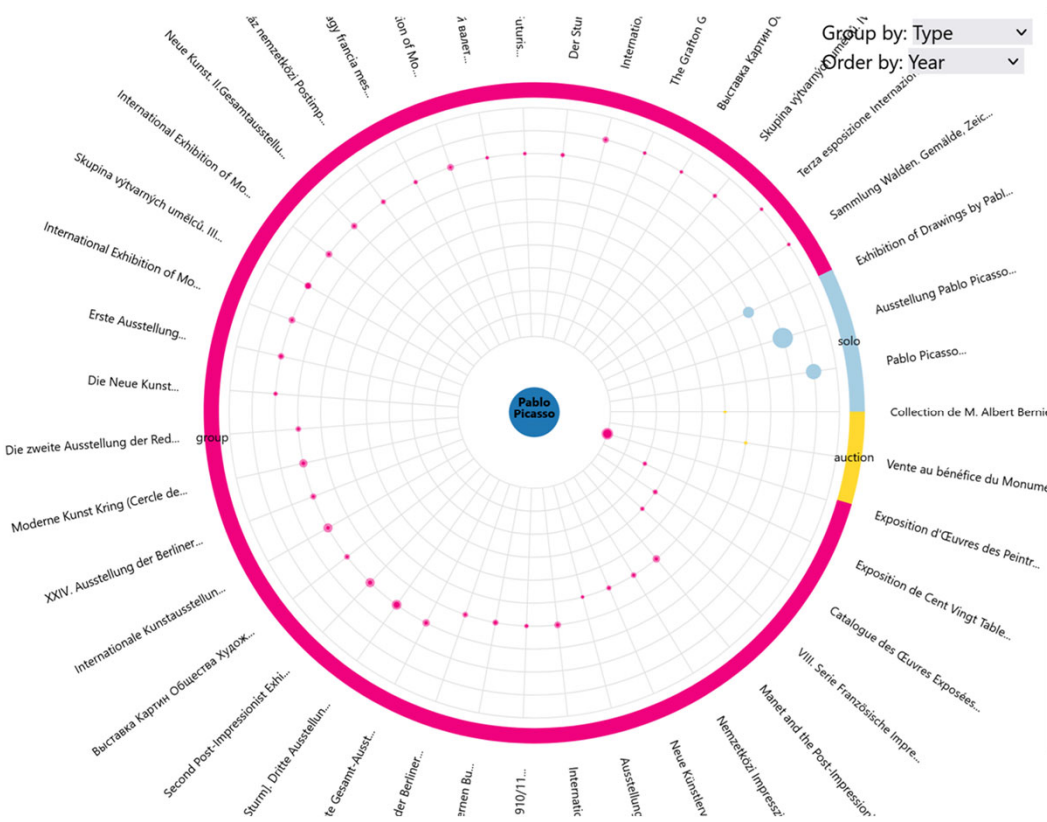

City

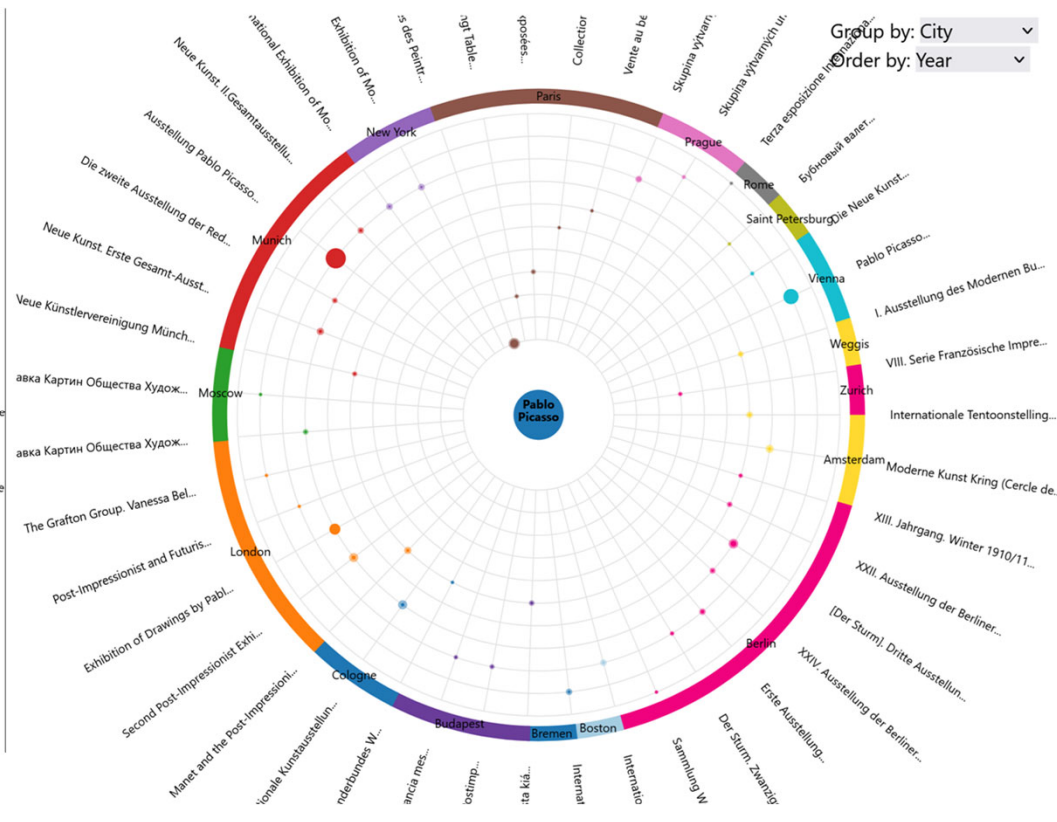

Multiple Perspectives

Pablo Picasso

Interactions

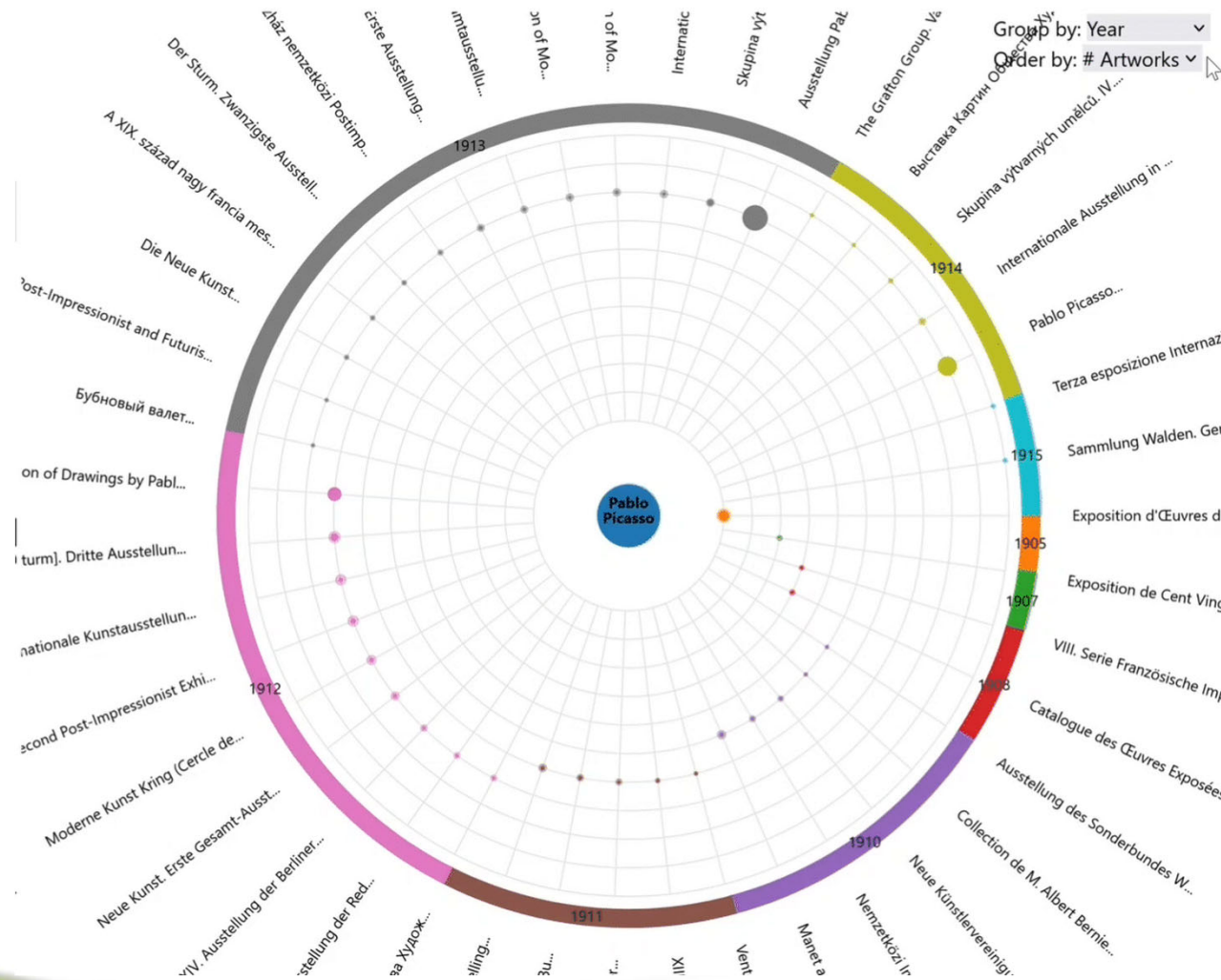

Comparative Analysis

Vassily Kandinsky and Gabriele Münter

Vassily Kandinsky (RU)
1866 (Moscow) - 1944 (Neuilly-sur-Seine)
57 exhibitions | 588 artworks

23 common exhibitions

Gabriele Münter (DE)
1877 (Berlin) - 1962 (Murnau)
28 exhibitions | 303 artworks

Type	Date	City	Country	Title	Catalogue Entries	Base %Entries	Compare %Entries	Artists	Host	Hosttype
group	1909	Munich	DE	Neue Künstlervereinigung München E.V., Turnus 1909-1910	137	10%	10%	14	Moderne Galerie (Heinrich Thannhauser)	art galleries
				Салон. Интернациональная выставка картин.						

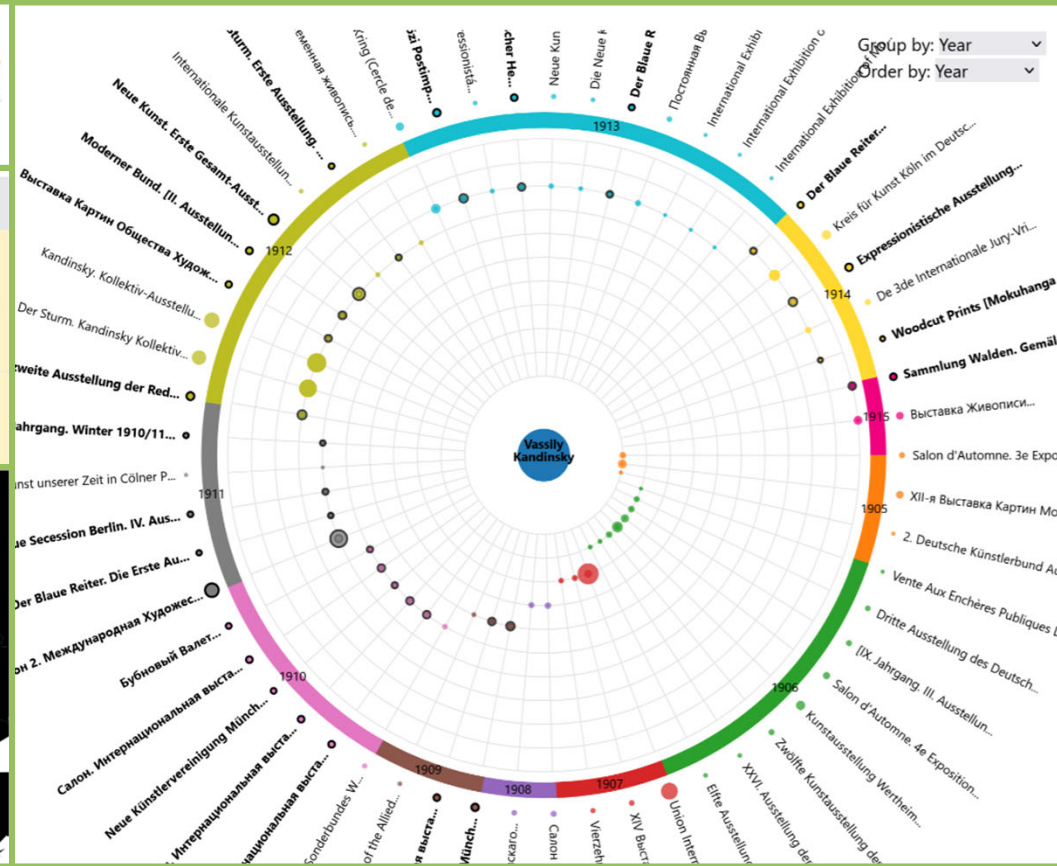

Content

Motivation & Contextualization

Data, Users, & Tasks → Information & Knowledge

Visual Analytics (VA)

Mixed-Initiative Process & Challenges

Guidance-Enriched VA

Models and Concepts

Exempels & Insights

Knowledge-Assisted VA

Models and Concepts

Exempels & Insights

Challenges & Opportunities

Conclusion



Generative AI ... LLM ::: Visualization

Prompt-to-Vis Systems

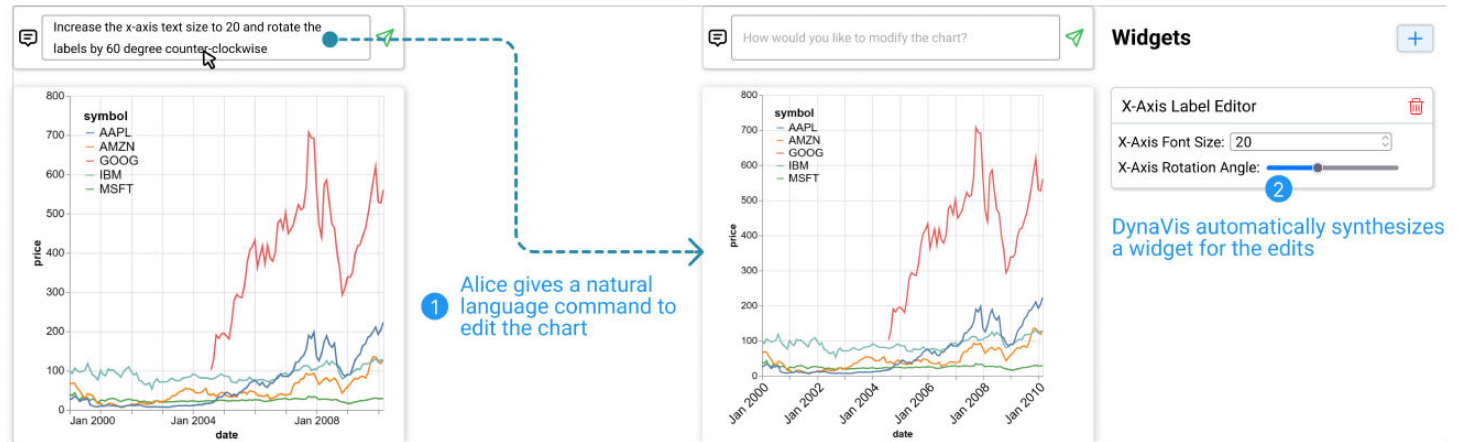
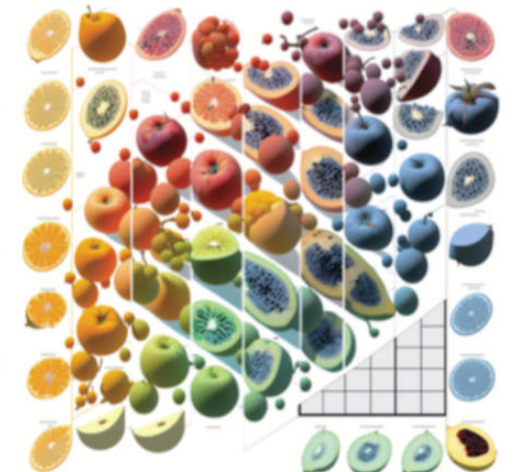

Image Synthesis for Vis

Treemap
"A treemap made of trees"



Scatterplot
"Should visualization researchers eat from the low-hanging fruit of generative models and accept the consequences?"



Generative AI ... LLM :: Visualization

[Bertini, 2025]

Narrative Sequences

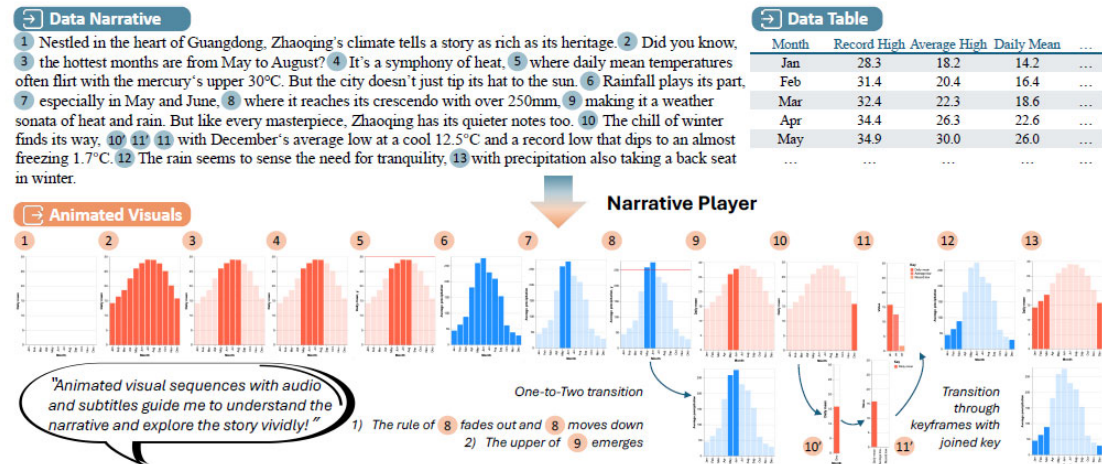

Evaluation Results of LLM

VisEval

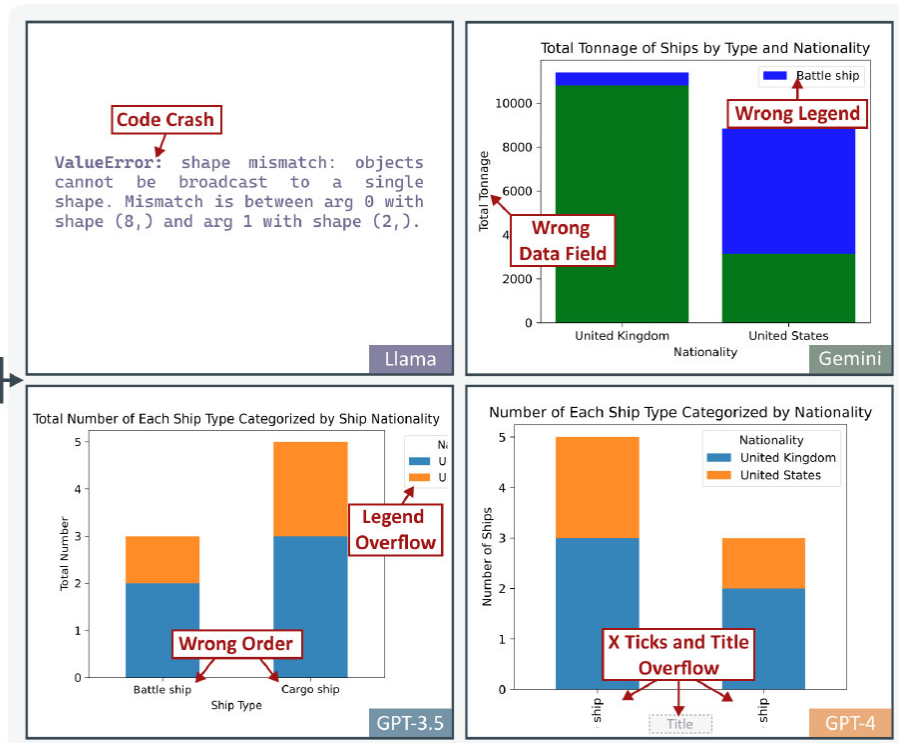

SWOT

[Agarwal and Sonbhadra 2025]

Weaknesses

Limited analytical reasoning & accuracy → hallucination

Computational cost & latency

Biases & interpretable issues

Blackbox nature → VA: transparency & explainability

Unclear domain knowledge integration

Fragmented implementation

Threats

Data privacy & security

Regulatory & ethical challenges

Over-reliance & skill degradation

Challenges and Opportunities

Agentic Visualization / Visual Analytics

“ ... interactive visual analysis systems that incorporate **autonomous agents** (whether AI-driven or rule-based) while maintaining **human agency** in the analytical process.” [Dhanoa, et al. 2025]

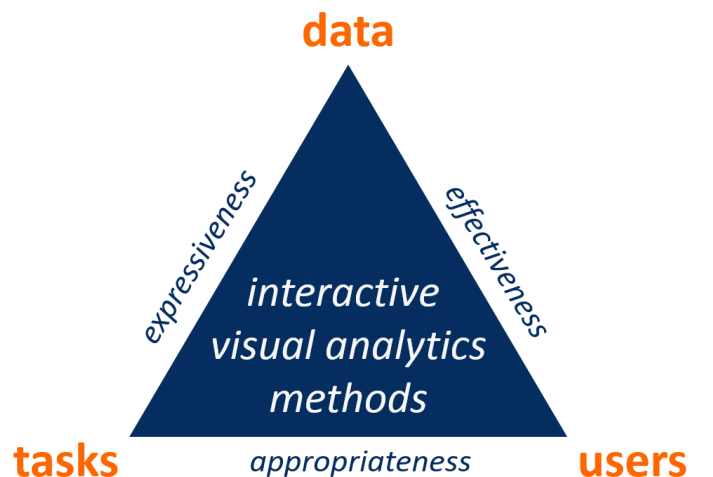
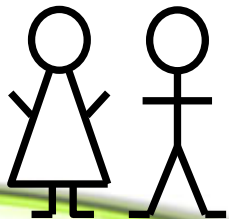
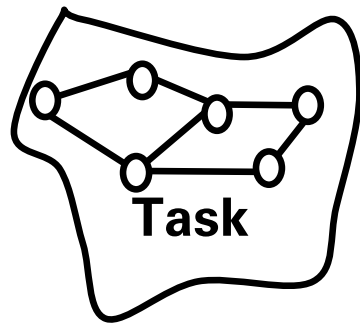

[Miksch & Aigner, 2014]

What?
data

1

Why?
user tasks

2

How?
visualization & interaction

3

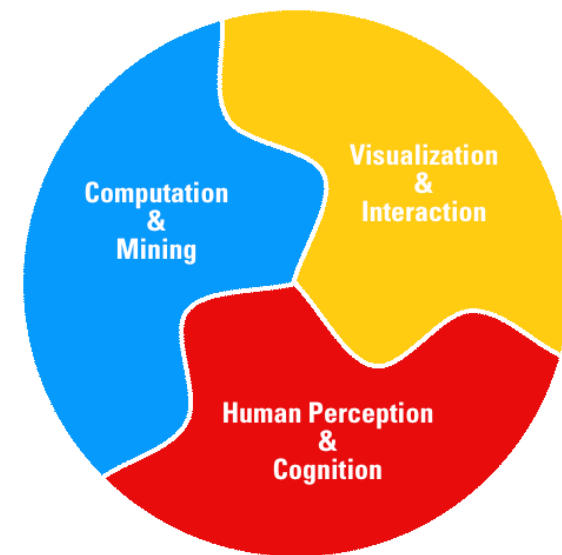

CHALLENGES & OPPORTUNITIES

Challenges & Opportunities

Towards Conceptual Models ::: Visual Analytics Knowledge-Assisted Visual Analytics

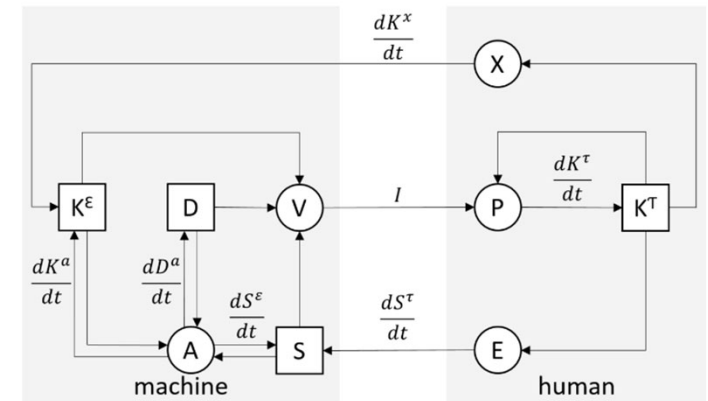

[Federico, et al. 2017]

Challenges & Opportunities

Towards Conceptual Models ::: Visual Analytics

Knowledge-Assisted Visual Analytics

Guidance-Enriched Visual Analytics

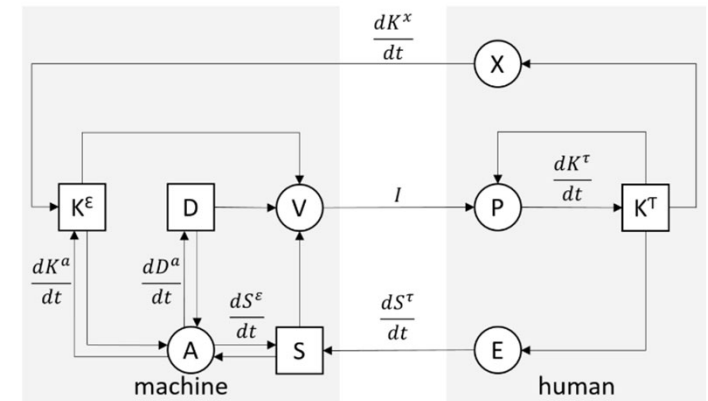

[Federico, et al. 2017]

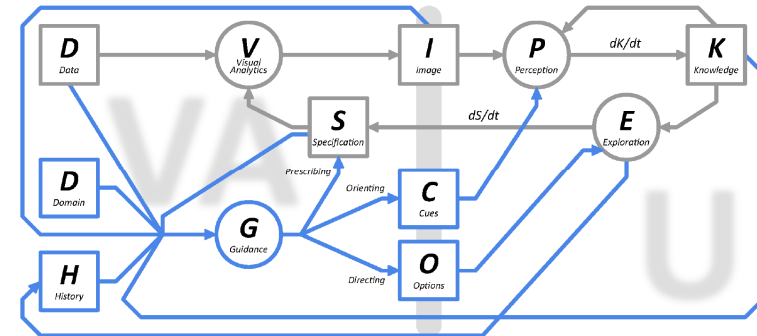

[Cedena, et al. 2019]

Challenges & Opportunities

Towards Conceptual Models ::: Visual Analytics

Knowledge-Assisted Visual Analytics

Guidance-Enriched Visual Analytics

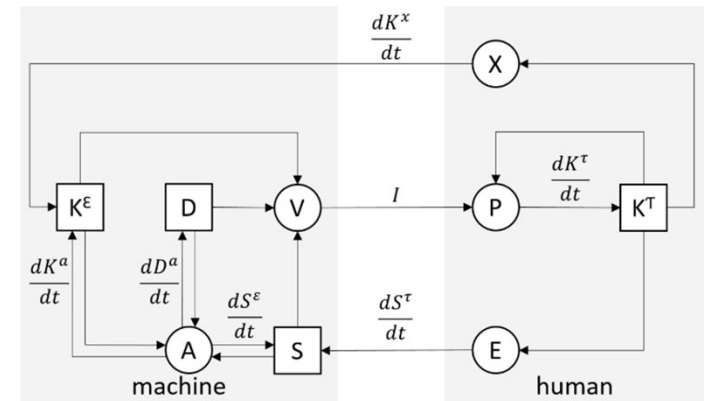

[Federico, et al. 2017]

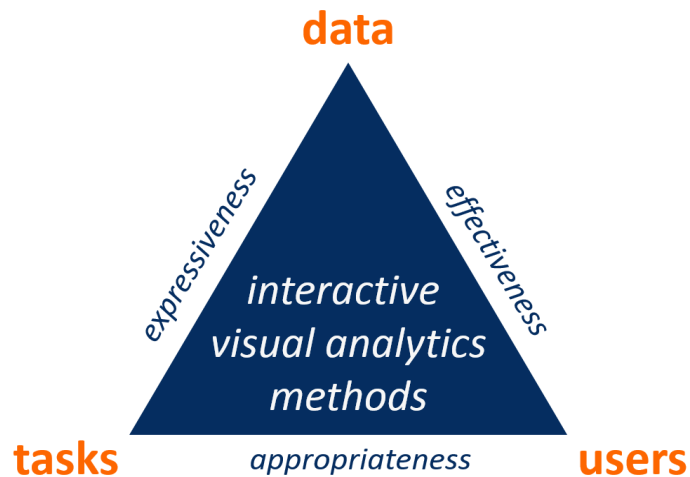

[Miksch & Aigner, 2014]

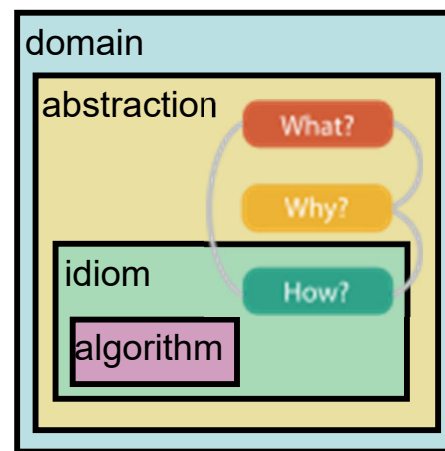

[Brehmer & Munzner, 2013]

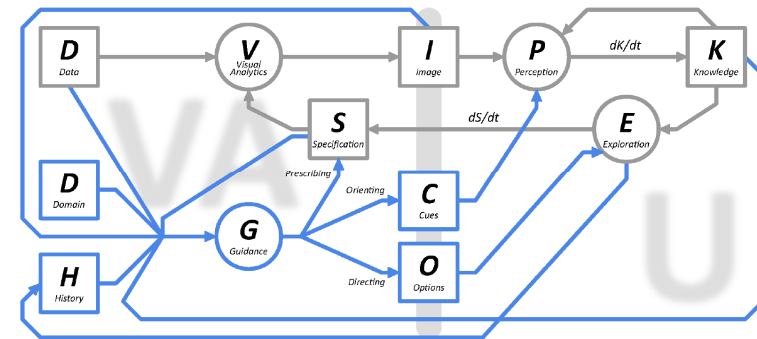

[Cedena, et al. 2019]

Challenges & Opportunities

Towards Conceptual Models ::: Visual Analytics

Knowledge-Assisted Visual Analytics
Guidance-Enriched Visual Analytics

Aspects

Data Quality
Data Provenance
Temporal Uncertainty
Science of Interaction

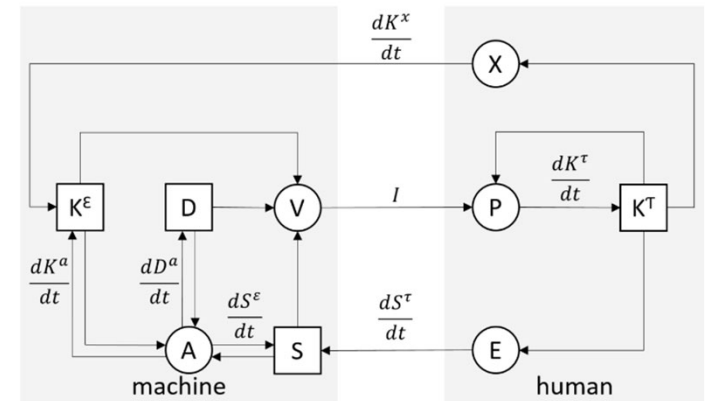

[Federico, et al. 2017]

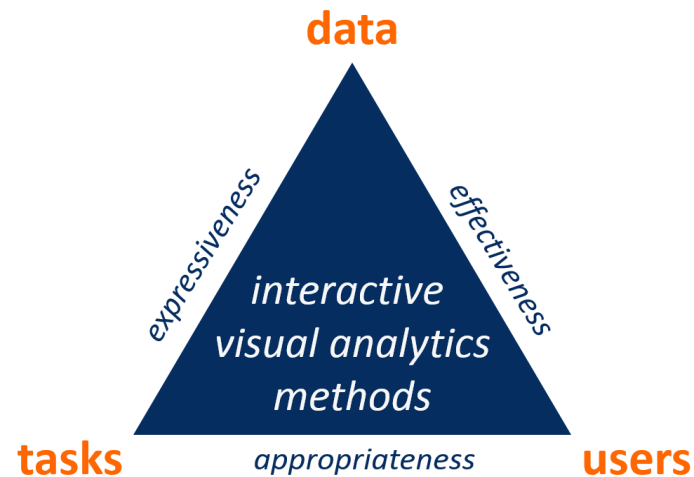

[Miksch & Aigner, 2014]

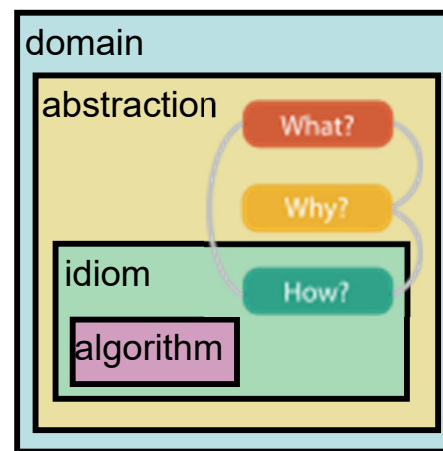

[Brehmer & Munzner, 2013]

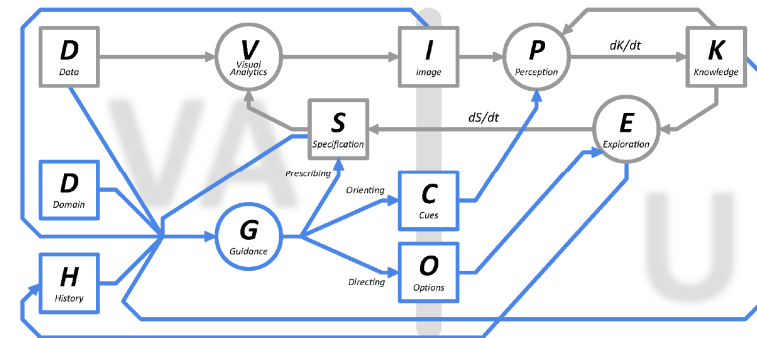

[Cedena, et al. 2019]

A Heuristic Approach to Value-Driven Evaluation of Visualizations

Emily Wall, Meeshu Agnihotri, Laura Matzen, Kristin Divis, Michael Haass, Alex Endert, and John Stasko

Abstract—Recently, an approach for determining the value of a visualization was proposed, one moving beyond simple measurements of task accuracy and speed. The value equation contains components for the time savings a visualization provides, the insights and insightful questions it spurs, the overall essence of the data it conveys, and the confidence about the data and its domain it inspires. This articulation of value is purely descriptive, however, providing no actionable method of assessing a visualization's value. In this work, we create a heuristic-based evaluation methodology to accompany the value equation for assessing interactive visualizations. We refer to the methodology colloquially as ICE-T, based on an anagram of the four value components. Our approach breaks the four components down into guidelines, each of which is made up of a small set of low-level heuristics. Evaluators who have knowledge of visualization design principles then assess the visualization with respect to the heuristics. We conducted an initial trial of the methodology on three interactive visualizations of the same data set, each evaluated by 15 visualization experts. We found that the methodology showed promise, obtaining consistent ratings across the three visualizations and mirroring judgments of the utility of the visualizations by instructors of the course in which they were developed.

Index Terms—Visualization evaluation, heuristics, value of visualization

IEEE TVCG 25(1):491-500, 2019

Evaluation

Qualitative
Quantitative
Heuristics
Multi-steps

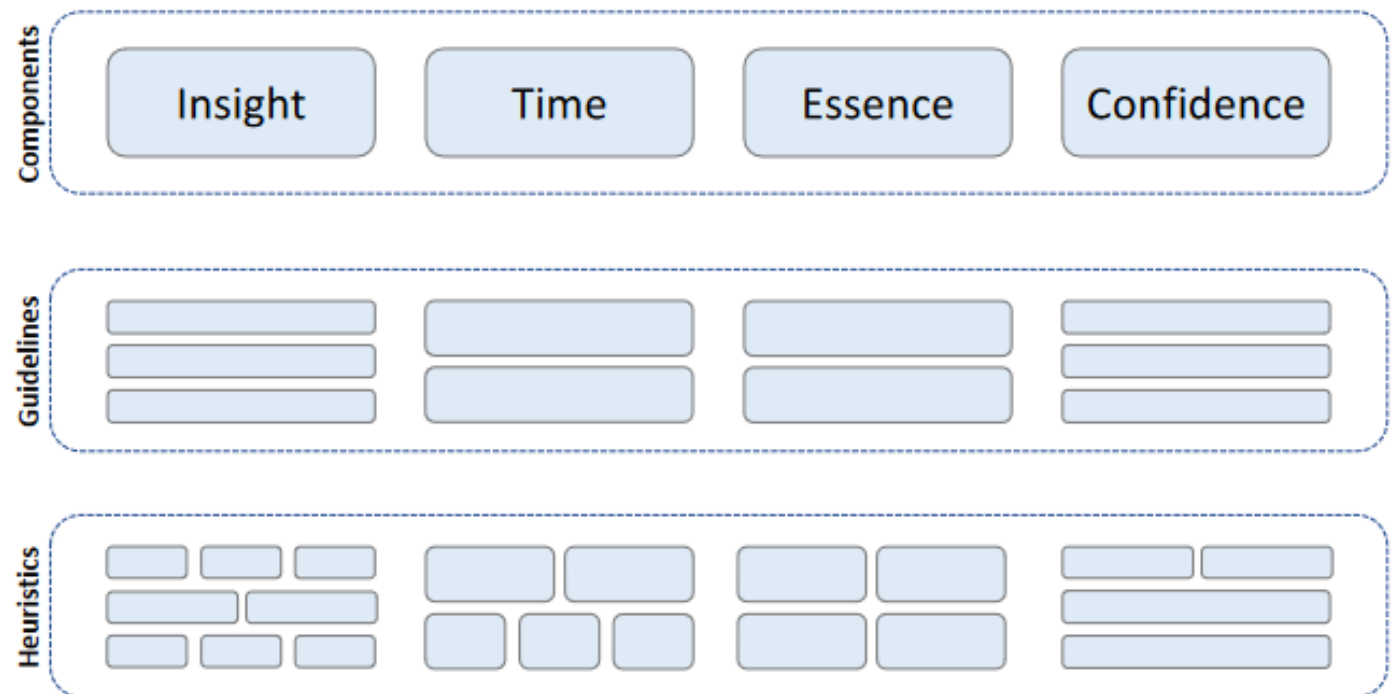

Challenges & Opportunities

Towards Conceptual Models ::: Visual Analytics

Knowledge-Assisted Visual Analytics

Guidance-Enriched Visual Analytics

Aspects

...

Evaluation

...

Explainable * *[van Harmelen, talk, August 2022]*

Faithful

Rational Reconstruction

Constructive

Social

→ How to Evaluate the Quality of Explanation: ???

Challenges & Opportunities

Towards Conceptual Models ::: Visual Analytics

Knowledge-Assisted Visual Analytics

Guidance-Enriched Visual Analytics

Aspects

...

Evaluation

...

Explainable * *[van Harmelen, talk, August 2022]*

...

Application domains

Health Care

Business Intelligence

Digital Humanities – Digital Art History

Financial Sectors

other disciplines of Natural, Social, and Economic Sciences

CONCLUSION



Visual Analytics – Process

[Keim, et al., 2008]

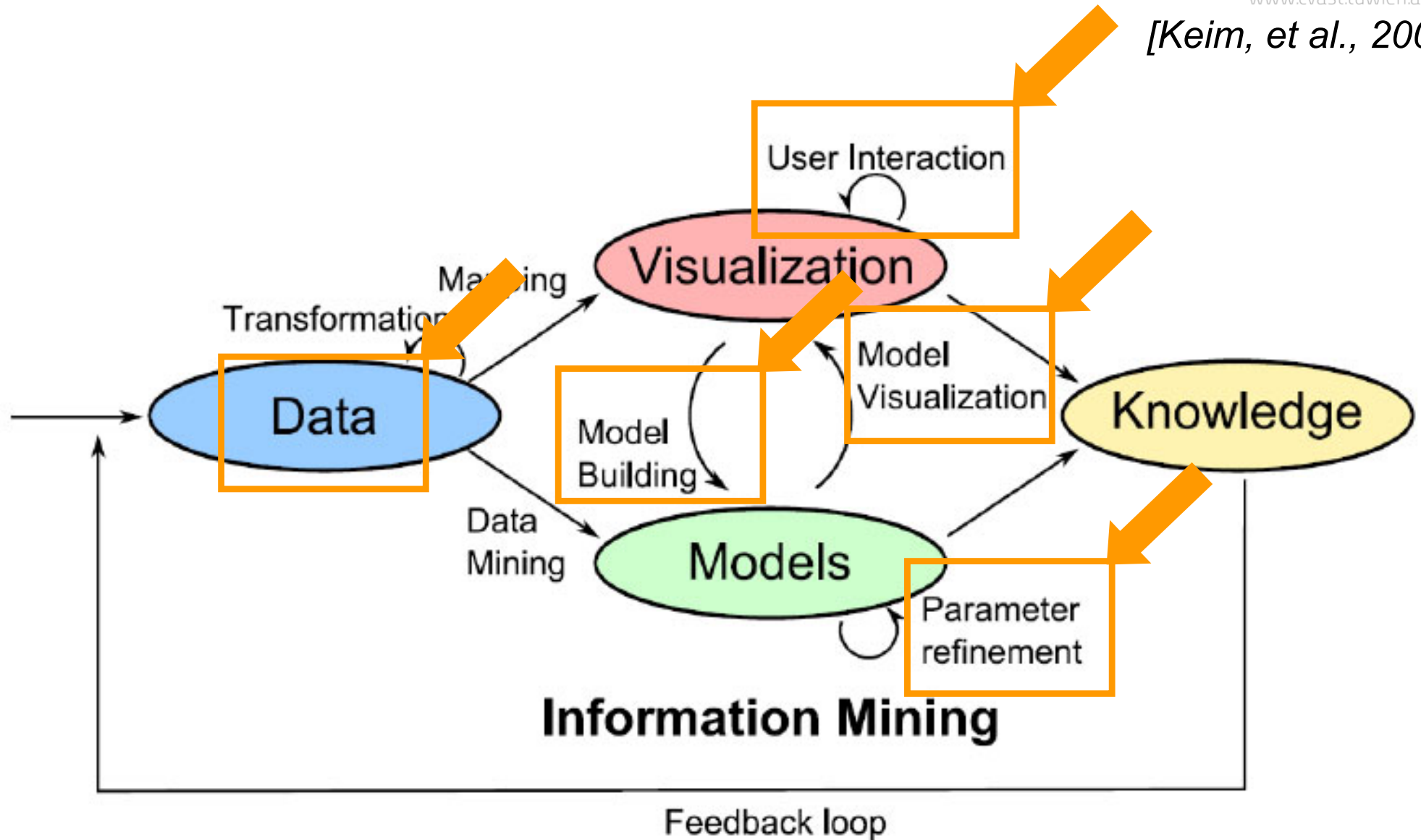

Conclusion

Visual Analytics –

Detect the Expected and Discover the Unexpected

What?

Data (time & space)

1

Why?

user tasks

2

How?

visualization & interaction

3

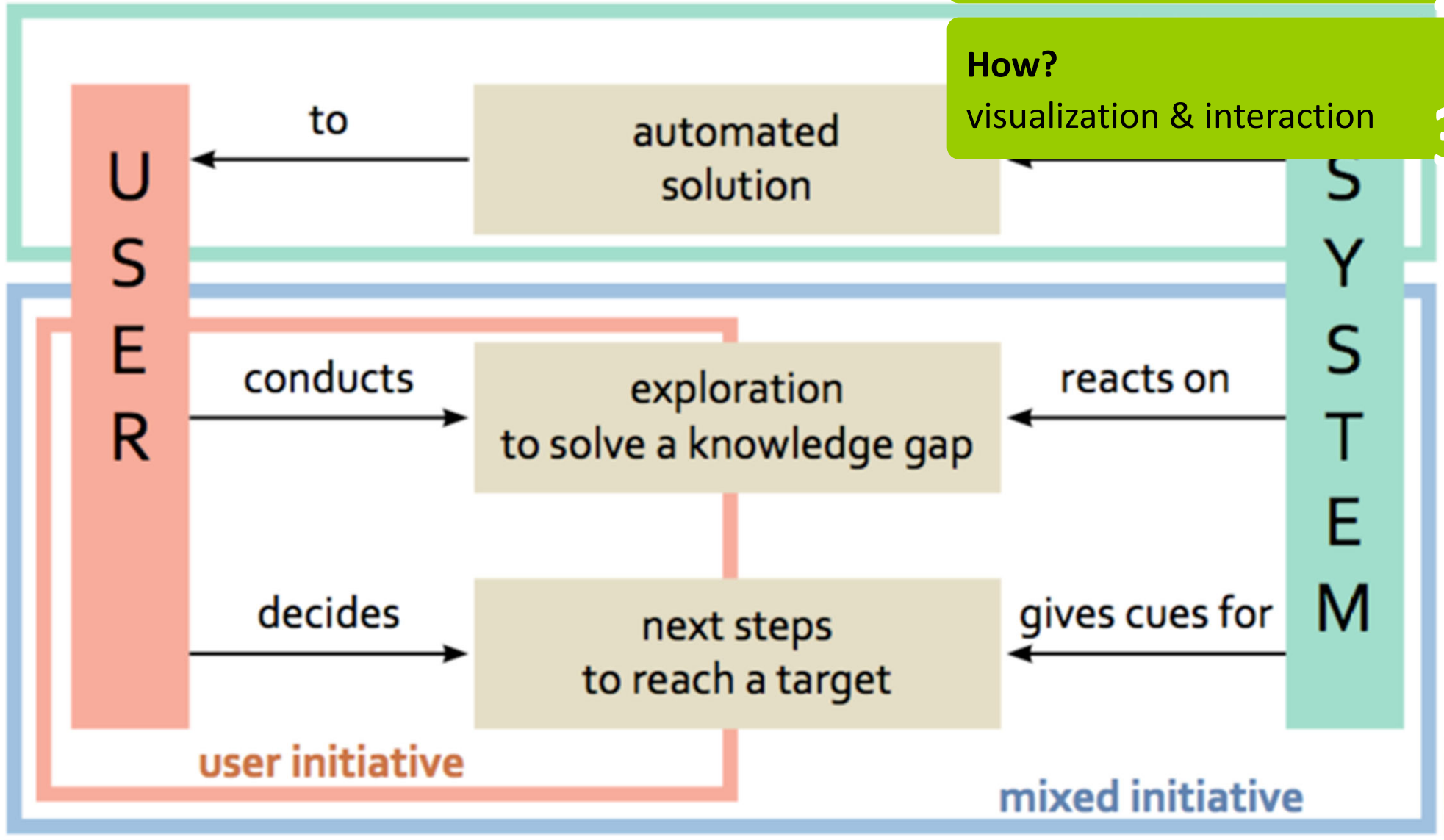



Open Access

011010010
01100110
111010100
001111010
001011010



Ch.3
Time & Time-Oriented Data



Ch.2
Historical Background

Ch.1
Crafting the Visualization of Time-Oriented Data





NOW WITH ~50% MORE CONTENT!

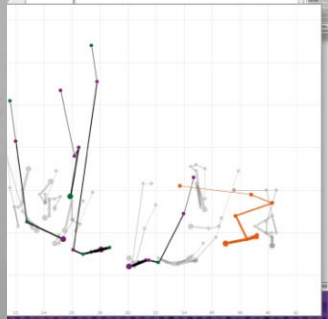
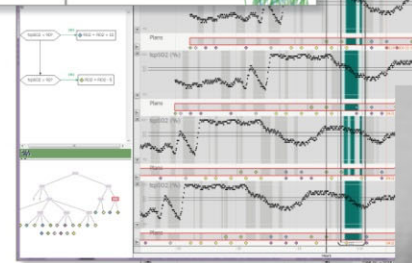
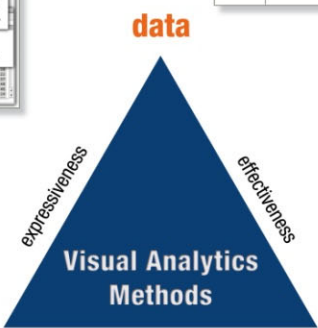
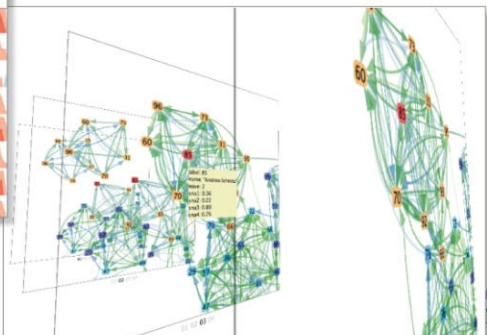
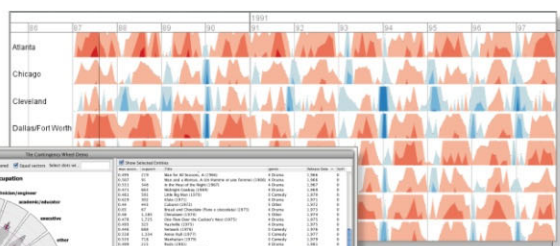

tasks/goals

appropriateness

users/audience

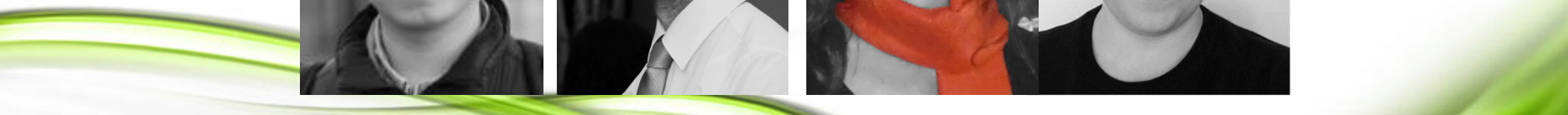
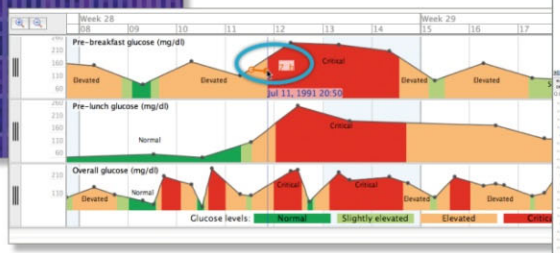
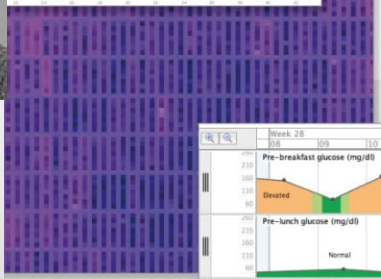
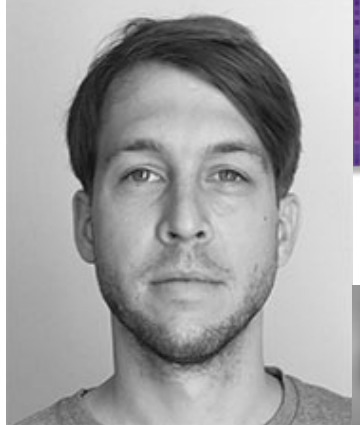

Thanks to

Alan Albert Alessio Alessio Alexander Alexander Alime Amin Andreas
Andreas Annette Arghad Barbara Barbara Ben Bilal Brain Burcu Carlo
Catherine Christian Christian Christian Claudio Daniel David Davide Dorna
Edeltraud Eduard Elisabeth Elpida Elske Eva Fabian Felix Florian Florian
Frank Franz Gennady Georg Georg Gerhard Gerhilde Guiseppe Hanna
Heidrun Helga Helwig Ingrid Jarke Jim Jimmy Johannes Jörn Jürgen Kai
Karl Katharina Klaus Krist Luca Lukas Manfred Mar Margit Maria Markus
Markus Martin Martin Matt Michael Michael Michael Mikko Monika Monika
Mor Nada Natalie Nikolaus Otto Panagiotis Paolo Paolo Patrick Peter Peter
Peter Rene Rita Robert Robert Robert Roberto Roger Ruth Sabine Salvo
Samson Silvana Simone Sophie Stefan Stefan Stephan Susanne Sylvia
Taowei David Theresia Thomas Tim Tom Victor Werner Wolfgang Yuval

... and many students and co-workers



Backbone of Research Project Ecosystem

CVAST
www.cvast.tuwien.ac.at

www.cvast.tuwien.ac.at



Laura Bassi Centre of Expertise
**Centre for Visual Analytics
Science & Technology**



SmartCT



GuidedVA



POLICUBE

KnoVA



SANE



IMMV



VIENA

EXPAND

FWF

Der Wissenschaftsfonds.

FWF

Der Wissenschaftsfonds.

FWF

Der Wissenschaftsfonds.

FWF

Der Wissenschaftsfonds.

FWF

Der Wissenschaftsfonds.

FWF

Der Wissenschaftsfonds.

FWF WEAVE

Der Wissenschaftsfonds.

FWF D-A-CH

Der Wissenschaftsfonds.

FWF PEEK

Der Wissenschaftsfonds.



Environmental Informatics
Doctoral College



MobiGuide
Guiding patients anytime everywhere



remine



VisuExplore
visualizing medical information



FFG
FORSCHUNG WIRKT.



DeVisOR



FFG
FORSCHUNG WIRKT.

DoRIAH



FFG
FORSCHUNG WIRKT.

FIT-IT [Visual Computing

FIT-IT [Visual Computing

THANK YOU!

